

Clarke Focus II Rider Autoscrubber

Nilfisk-Alto Scrubtec R6 Rider Autoscrubber



Service Manual

Clarke® model numbers:

56114000	Focus II Rider 28 D Base
56114001	Focus II Rider 34 D OBC Base
56114002	Focus II Rider 34 D Base
56114003	Focus II Rider 28 B Base
56114009	Focus II Rider 28 B OBC Base
56114010	Focus II Rider 28 D OBC Base

Nilfisk-Alto model numbers:

56114004	Scrubtec R 6-71 28D
56114005	Scrubtec R 6-71C 28C
56114006	Scrubtec R 6-86 34D
56114008	Scrubtec R 6-100 40D



English

08/12 Updated 08/14 Form No. 56043159

Contents

General Information	.6
Service Manual Purpose and Application	.6
Revision History	.6
Other Reference Manuals and Information Sources.	.6
Conventions.	.6
Cautions and Warnings	.6
<i>Symbols</i>	6
<i>General Safety Instructions</i>	7
Transporting the Machine	.8
Nameplate	.9
Know Your Machine — Major components:	.9
General Specifications	10
Fastener Torque Specifications	11
Maintenance Schedule.	11
<i>Lubricating the Machine</i>	12
<i>Diagnostic and Service Tools</i>	12
Chassis System	15
Functional Description	15
Control System	16
Functional Description	16
<i>Control Panel</i>	16
<i>Main Machine Controller</i>	17
Component Locations	18
Main Machine Controller Programming	19
<i>Programming Menu Outline</i>	19
<i>Quick Start: Navigating the Hidden Menus</i>	20
<i>Deck Type</i>	20
<i>Battery Charger</i>	20
<i>Chemical (Detergent) Selection.</i>	20
<i>Detergent Mode.</i>	20
<i>Vacuum Selection</i>	21
<i>Low Voltage Cutout</i>	21
<i>Max (Maximum) Scrub Speed</i>	21
<i>Lockout Brush Pre (Pressure)</i>	21
<i>Lockout Sol (Solution) Flows</i>	21
<i>Chemical (Detergent) Rate Bias</i>	21
<i>Deck Down Time.</i>	21
<i>Restore Defaults.</i>	21
<i>Display Rev Level</i>	22
<i>Fault Recall.</i>	22
<i>Fault Detection</i>	22
<i>Service Test Mode</i>	22
<i>Backup Alarm Vol (Volume).</i>	22
<i>FWD Alarm Vol (Forward)</i>	22
<i>Horn Volume.</i>	22
<i>Panel Test</i>	22
Troubleshooting Guide.	22
<i>Main Controller Error Codes</i>	23

<i>Service Test Mode</i>	25
<i>Test Mode Display</i>	25
<i>Test Mode Functions</i>	25
<i>Sample Shop Voltage Measurements</i>	26
Controller I/O Table	28
Removal and Installation.	29
<i>Main Control Board</i>	29
Electrical System	30
Functional Description	30
<i>Safety Circuit</i>	30
<i>Description Of The Low-Voltage Cutout Feature</i>	31
Onboard Battery Chargers	31
<i>Interlock Circuit</i>	31
<i>S.P.E. Charging Profiles and Charging Progress</i>	31
<i>Delta-Q Charging Profiles and Charging Progress</i>	32
<i>Delta-Q Battery Charging Profile Table</i>	32
Component Locations	34
Maintenance and Adjustments	35
<i>Charging Batteries</i>	35
<i>Extending Battery Life</i>	35
Troubleshooting	36
<i>Battery Testing</i>	36
Removal and Installation.	36
<i>Batteries</i>	36
<i>Electrical Panel Cover</i>	37
Specifications	37
<i>Wet Cell Battery Specifications:</i>	37
<i>Wet Cell Battery Charger Specifications</i>	37
Wiring Diagrams	37
<i>Wiring (Ladder) Diagram: 56114061 Rev C (Early, before machine SN 3000167142)</i>	38
<i>Sheet 1 of 2</i>	38
<i>Sheet 2 of 2</i>	39
<i>Wiring (Ladder) Diagram 56114404 Rev A (Late, beginning with machine SN 3000167142)</i>	40
<i>Sheet 1 of 2</i>	40
<i>Sheet 2 of 2</i>	41
<i>Wiring Harness Diagram: 56114062 Rev B (Early, before machine SN 3000167142)</i>	42
<i>Wiring Harness Diagram: 56114405 Rev A (Late, beginning with machine SN 3000167142)</i>	43
Connector Pinouts	44
Options and Accessories	47
Recovery System	48
Functional Description	48
<i>Vacuum Motor and Recovery Tank</i>	48
<i>Vacuum Motor Control Circuit Overview</i>	49
Troubleshooting	50
<i>Vacuum Suction Test</i>	51
Removal and Installation.	52
<i>Recovery Tank</i>	52
<i>Vacuum Motor</i>	53
Specifications	54
Special Tools	54

Scrub System: Disc, Cylindrical, & Boost	55
Functional Description	55
<i>Deck Lift</i>	55
<i>Drive Motors</i>	55
<i>Disc Deck</i>	55
<i>Cylindrical Deck (Nilfisk-Alto models only)</i>	56
<i>Boost Deck (Clarke models only)</i>	56
<i>Circuit Overview</i>	56
<i>Scrub Deck Motors</i>	56
<i>Deck Lift Actuator</i>	57
Maintenance and Adjustment.	58
<i>Lift Actuator Limit Adjustment</i>	58
Removal and Installation.	59
<i>Scrub Deck</i>	59
<i>Deck Lift Actuator</i>	61
<i>Lead Nut and Spring Orientation</i>	62
<i>Brush Motor Contactor</i>	63
<i>Disc Deck Motor</i>	64
<i>Cylindrical Deck Motor</i>	64
<i>Boost Deck Motor</i>	65
Specifications	66
Special Tools	66
Solution System	67
Functional Description	67
<i>Solution Solenoid</i>	67
<i>Detergent Models</i>	67
<i>Circuit Overview</i>	68
<i>Solenoid Valve Circuit</i>	68
<i>Detergent Pump</i>	68
<i>Solution System Schematic</i>	68
Removal and Installation.	69
<i>Solution Valve, Filter, and Solenoid</i>	69
<i>Detergent Pump</i>	70
Specifications	70
Squeegee System	71
Functional Description	71
<i>Squeegee Lift Actuator</i>	71
<i>Squeegee</i>	71
Maintenance and Adjustment.	72
<i>Squeegee Blade Cleaning and Inspection</i>	72
<i>Squeegee Trim Adjustment</i>	72
<i>Actuator Limit Adjustment</i>	73
Removal and Installation.	74
<i>Rear (main) Squeegee Blade Reversal or Replacement</i>	74
<i>Front Squeegee Blade Reversal or Replacement</i>	75
<i>Squeegee Lift Actuator</i>	76
Specifications	76
Wheel System, Non-Traction	77
Functional Description	77
Removal and Installation.	77

Wheel System, Traction	78
Functional Description	78
<i>Drive Pedal Sensor</i>	78
<i>Speed Limiting Potentiometer</i>	78
<i>Drive Motor System Function</i>	79
<i>Wheel Drive Controller J10 Pinout Functions</i>	80
Troubleshooting	81
<i>Wheel Drive Controller Error Codes</i>	82
Removal and Installation.	83
<i>Drive Controller</i>	83
<i>Drive Wheel Assembly</i>	84
<i>Drive Motor, Brushes, and Electromechanical Brake</i>	87
<i>Carbon Brushes</i>	88
<i>Drive Tire</i>	89
<i>Steering Chain</i>	91
Specifications	92
Special Tools	93
<i>Curtis 1311 Programmer PN 56409441</i>	93
<i>Tire “Puller” Kit PN 56422174</i>	93

General Information

Service Manual Purpose and Application

This Service Manual is a resource for professional service technicians. It provides information for understanding how the machine operates, where components are located, basic troubleshooting, maintenance and mechanical service operations.

The cover page of this manual lists each machine part number that the manual applies to. Compare the part number of the machine you are working on to the model numbers listed on the cover page to be sure you are using the correct manual.

Revision History

- 11/13
 - Electrical System: Updated wiring diagram 56114061 Rev B to Rev C.
 - Control System: Explained that Main Machine Controller code 07 can be caused by failing to program controller after installing a second vacuum motor.
 - General Information, General Specifications: Added metric values
 - Wheel System, Traction, Special Tools: Added Tire Puller Kit part number and photo.
- 07/14
 - Control System: Clarified programming options for S.P.E charger VS Delta-Q
 - Electrical System: Added information for Delta-Q IC650 onboard battery charger and added wiring diagrams.

Other Reference Manuals and Information Sources

The following documents contain parts information and instructions for machine operation:

- Instructions for Use: OM56091040 through OM56091046
- Parts List: PL56042589 and PL56042590

Conventions

Forward, backward, front, rear, left or right are intended with reference to the operator's position, that is to say in operating position with the hands on the handlebar.

Cautions and Warnings

Symbols

It is important for you to read and understand this manual. The information it contains relates to protecting your safety and preventing problems. The symbols below are used to help you recognize this information.



Danger: Indicates a potentially hazardous situation which, if not avoided, will result in death or serious injury.



Warning: Indicates a potentially hazardous situation which, if not avoided, could result in death or serious injury.



Caution: Indicates a potentially hazardous situation which, if not avoided, could result in minor or moderate injury.

Caution: When used without the Safety Alert Symbol, indicates a potential situation which, if not avoided, could result in property or machine damage.

General Safety Instructions



Warning!

- This machine should be used only by properly trained and authorized persons.
- Never work under a machine without safety blocks or stands to support the machine.
- Keep sparks, flame and smoking materials away from batteries. Explosive gases are vented during normal operation.
- Charging the batteries produces highly explosive hydrogen gas. Charge batteries only in well-ventilated areas away from open flame. Do not smoke while charging the batteries.
- Remove all jewelry when working near electrical components.
- Do not dispense flammable cleaning agents, operate the machine on or near these agents, or operate in areas where flammable liquids exist.



Caution!:

- When operating this machine, ensure that third parties, particularly children, are not endangered.
- Turn the key switch off (O) and disconnect the batteries before servicing electrical components.
- Turn the key switch off (O) and remove the key, before changing the brushes, and before opening any access panels.
- This machine is not suitable for picking up hazardous dust.
- Do not use on surfaces having a gradient exceeding that marked on the machine.
- While on ramps or inclines, avoid sudden stops when loaded. Avoid abrupt sharp turns. Use low speed down hills. Clean only while ascending (driving up) the ramp.
- Before performing any service function, carefully read all instructions pertaining to that function.
- Do not leave the machine unattended without first turning the key switch off (O), removing the key and securing the machine.
- Take precautions to prevent hair, jewelry, or loose clothing from becoming caught in moving parts.
- Only use the brushes provided with the appliance or those specified in the instruction manual. The use of other brushes may impair safety.
- Refer to the battery charger OEM product manual for additional specific battery charger warnings.

Caution!:

- This machine is not approved for use on public paths or roads.
- Do not use scarifier discs or grinding stones. These can damage the machine and the floor surface.
- Turn the key switch off (O) and remove the key, before changing the brushes, and before opening any access panels.
- Use caution when moving this machine at or below freezing temperature conditions. Any water in the solution, recovery or detergent tanks or in the hose lines could freeze, causing damage to valves and fittings. Flush with windshield washer fluid.
- The batteries must be removed from the machine before the machine is scrapped. The disposal of the batteries should be safely done in accordance with your local environmental regulations.
- Do not clean this machine with a pressure washer.
- All doors and covers are to be positioned as indicated in the instruction manual before using the machine.

Transporting the Machine



Caution: Before transporting the machine on an open truck or trailer, make sure that the machine is tied down securely and all access doors and covers are secured (tape and strap as needed).

The actual procedure for transporting the machine will vary depending on the mode of transport. Follow these general guidelines as applicable to the situation.

- If the machine is not operational or cannot be moved under its own power, you must manually release the brake. To release the brake, move the release handle (27) outward and insert an object, such as a screw driver, behind the lever to keep it deactivated.
- Drain the recovery and solution tanks.
- If transport will occur below freezing temperatures, place a small amount of environmentally friendly antifreeze in the recovery tank, solution tank, and solution lines. After transport, make sure to dispose of the used antifreeze according to local regulations.
- Remove the squeegee from the machine ([page 74](#)). This is required to access the rear hold down points and also protects the squeegee during loading, unloading, and transport.
- If the loading, unloading, or transport operations pose a risk for damage to the scrub deck, then remove the scrub deck ([page 59](#)).
- Make sure the recovery tank is securely fastened in place, or removed from the machine and transported separately.
- Make sure the recovery tank cover is securely held closed or removed from its hinges.
- Secure the machine to the transport using the anchor points shown below.

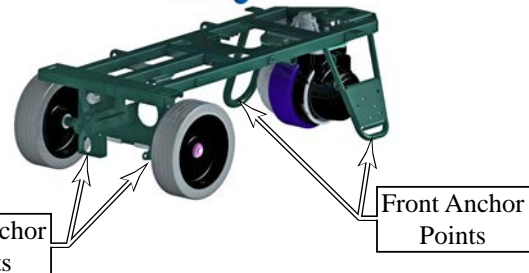

General Machine Description

The Clarke Focus II Rider/Scrubtec 6 is a compact battery power ride on floor scrubber. The machine can be equipped with a 28 inch (71 cm) disc, 34 inch disc, 28 cylindrical, 28 inch BOOST or 38 inch Disc scrub deck. The machine may also be equipped with an onboard detergent mixing system. This system stores concentrated detergent on the machine and meters the appropriate quantity of concentrated detergent and mixes it on the machine with water from the solution tank. The machine can be equipped with wet acid (flooded) or AGM (maintenance free) batteries and charged with either shelf or on board battery chargers

Nameplate

The nameplate contains important identification information which will be needed when ordering parts: Model (Name), Part No. (Part number of the machine which is often referred to as the “Model Number”), and Serial Number.



Know Your Machine — Major components:

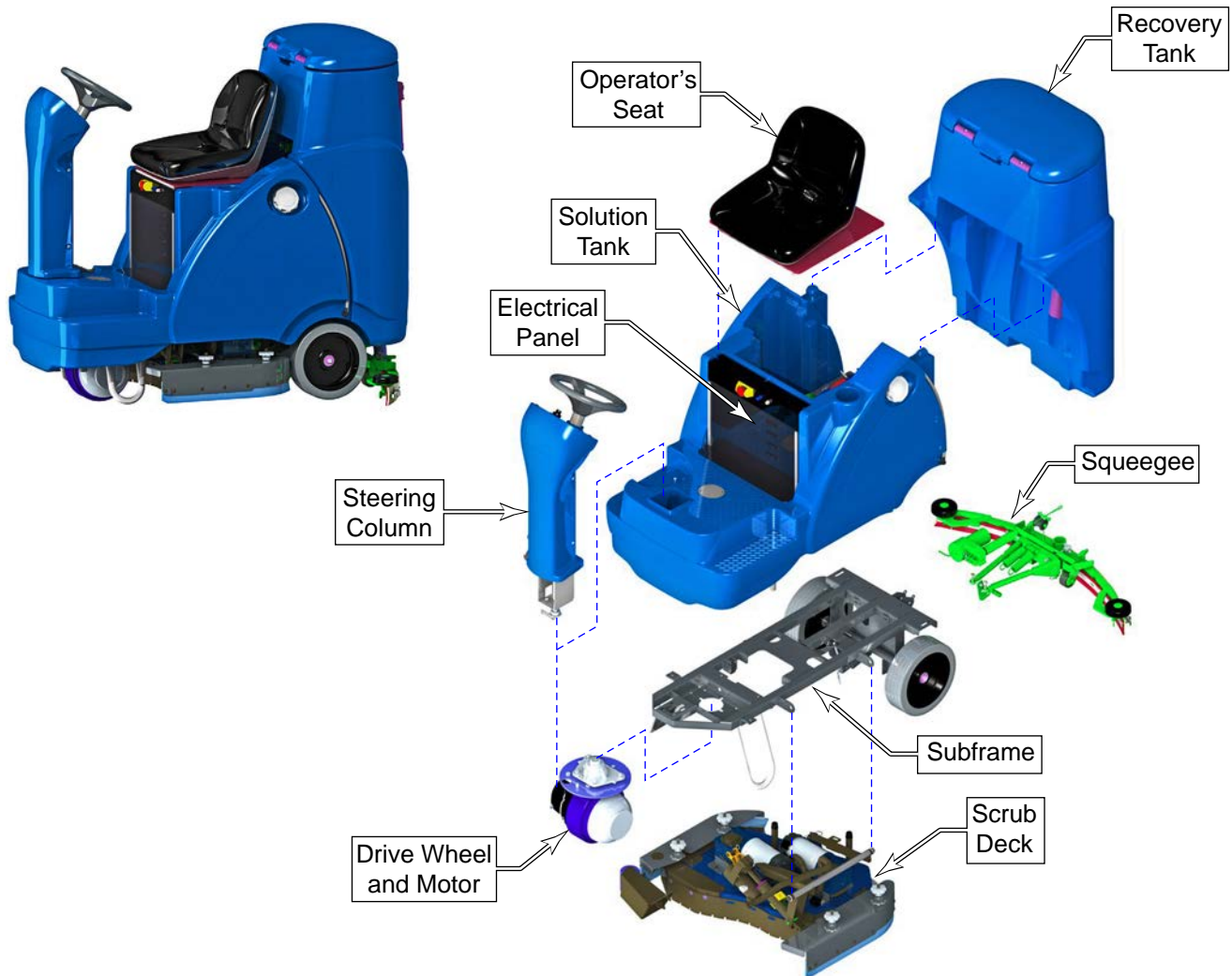

General Specifications

Specifications					
Model Category	28" Disc	28" Boost	28" Cyl.	34" Disc	38" Disc
Model Name	Focus II 28 D Scrubtec R 6 71	Focus II 28 B	Scrubtec R 6 71C	Focus II 34 D Scrubtec R 6 86	Scrubtec R 6 100
Model Number	56114000 56114010 56114004	56114003 56114009	56114005	56114002 56114001 56114006	56114008
Battery Voltage	24 Volts				
Protection Grade	IPX3				
Sound Pressure Level IEC 60335-2-72: 2002 Amend. 1:2005, ISO 11201	68.3dB LpA 3dB KpA	68.6dB LpA 3dB KpA	68.3dB LpA 3dB KpA	68.3dB LpA 3dB KpA	68.3dB LpA 3dB KpA
Gross Weight	1,341 lbs 608 kg	1,371 lbs 622 kg	1,359 lbs 616 kg	1,350 lbs 613 kg	1,603 lbs 727 kg
Maximum Wheel Floor Loading (front)	152 psi (1.05 N/mm ²)				
Maximum Wheel Floor Loading (right rear)	193 psi (1.33 N/mm ²)				
Maximum Wheel Floor Loading (left rear)	154 psi (1.06 N/mm ²)				
Vibrations at the Hand Controls (ISO 5349-1)	0.181 m/s ²	0.386 m/s ²	0.181 m/s ²	0.181 m/s ²	0.181 m/s ²
Vibrations at the Seat (EN 1032)	0.014 m/s ²	0.132 m/s ²	0.014 m/s ²	0.014 m/s ²	0.014 m/s ²
Gradeability Transport	12.5% (7.1°)				
Gradeability Cleaning	7.9% (4.5°)				
Height	54.8" (139 cm)				
Length	60.5" (154 cm)				
Width at Deck	32.1" (82 cm)	32.1" (82 cm)	32.8" (83 cm)	36.6" (93 cm)	42.1" (107 cm)
Width at Squeegee	32.5" (83 cm)	32.5" (83 cm)	32.5" (83 cm)	41.3" (105 cm)	46.3" (118 cm)



Fastener Torque Specifications

Standard Torque Specifications (unless otherwise specified)	Size	Plated Steel	Stainless Steel
	#10	42 in.-lb.	28 in.-lb.
	1/4"	100 in.-lb.	67 in.-lb.
	5/16"	17 ft.-lb.	11 ft.-lb.
	3/8"	31 ft.-lb.	20 ft.-lb.
	1/2"	75 ft.-lb.	50 ft.-lb.
	3/4"	270 ft.-lb.	180 ft.-lb.
	M5	61 in.-lb.	36 in.-lb.
	M6	9 ft.-lb.	62 in.-lb.
	M8	22 ft.-lb.	13 ft.-lb.
	M10	44 ft.-lb.	25 ft.-lb.
M12	70 ft.-lb.	40 ft.-lb.	

Maintenance Schedule

Maintenance intervals given are for average operating conditions. Machines used in severe operational environments may require service more often.

Maintenance Item	Interval			
	Daily	Weekly	Monthly	Yearly
Charge Batteries	•			
Check/Clean Tanks & Hoses (clean recovery tank switches & vacuum inlet screen)	•			
Check/Clean/Rotate the Brushes/Pads	•			
Check/Clean the Squeegee	•			
Clean Hopper on Cylindrical System	•			
Check Battery Cell Water Level (does not apply to gel cell batteries)		•		
Inspect Scrub Housing Skirts		•		
If so equipped, replace the boost deck isolators				250 hours
Inspect and clean Solution Filter		•		
Clean Solution Manifolds on Cylindrical System		•		
Purge Detergent System (if present)		•		
Lubricate the Machine			•	
Check Vacuum Motor Carbon Brushes				300 hours
Check Brush Motor Carbon Brushes				500 hours
Check Drive Motor Carbon Brushes				500 hours

Note: See the individual machine system sections for maintenance information.

Carbon Brush Notes:

- The original (new) length of each carbon brush is 1" (25.4mm) on brush and wheel drive motors.
- Replace carbon brushes when shorter than 3/8" (10mm) {1/4" (6mm) for drive motor} to obtain the same motor efficiency as new brushes.
- **Important:** Motor damage resulting from failure to service the carbon brushes is not covered under warranty. See the Limited Warranty Statement.

Lubricating the Machine

- Once a month, apply light machine oil to lubricate the components marked by **(OL)** below:
- Once per quarter Grease the components marked by **(GR)** below.

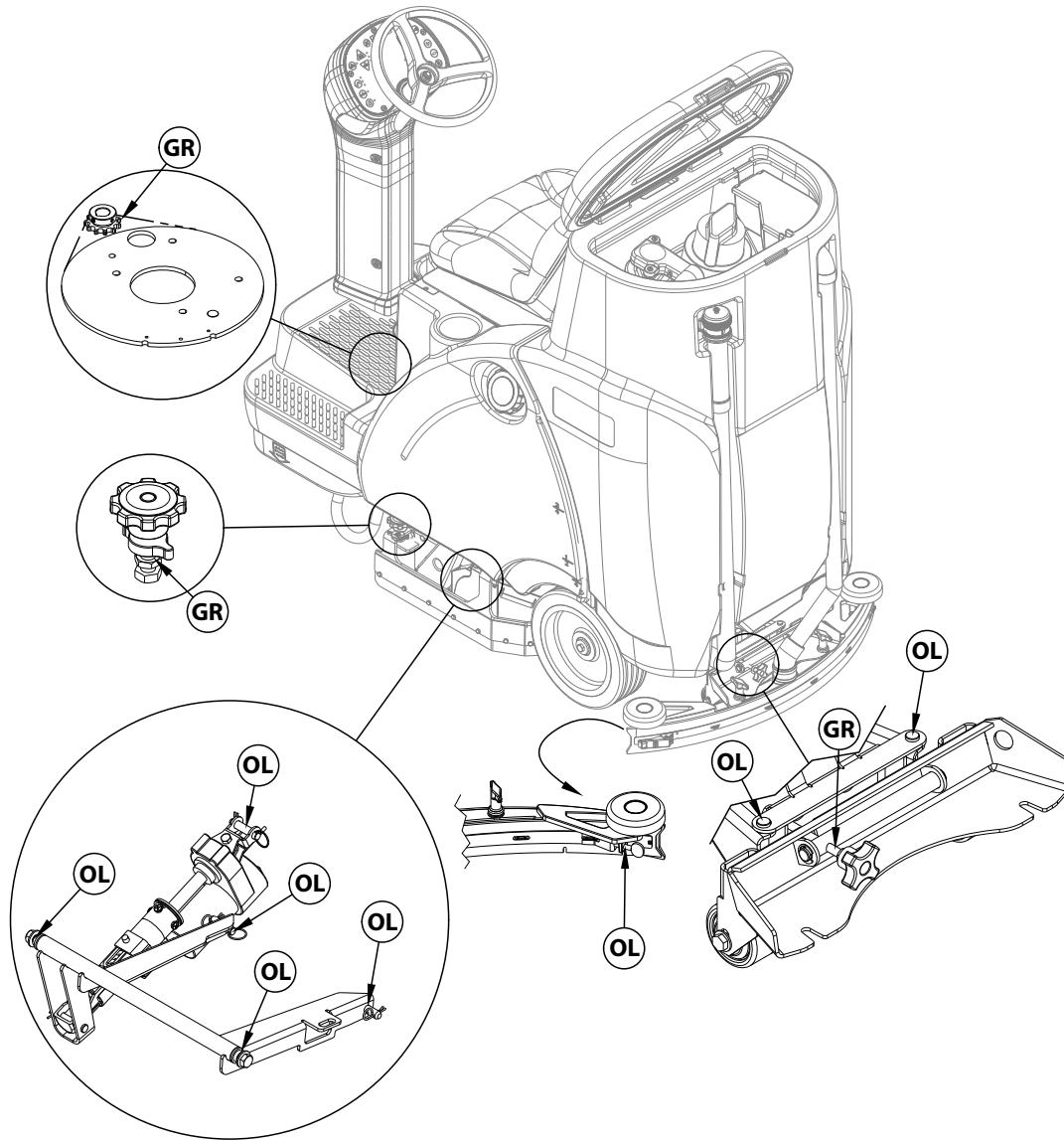

Diagnostic and Service Tools

In addition to a full set of metric and standard tools, the following items are required in order to successfully and quickly perform troubleshooting and repair of Nilfisk-Advance Industrial floor cleaning equipment.

- Laptop computer loaded with current version of EzParts, Adobe Reader and (preferably cellular) internet access
 - Digital volt ohmmeter (DVOM) with DC current clamp
 - Hydrometer
 - Battery load tester for checking 12V and 6V batteries.
 - Static control wrist strap
 - Set of torque wrenches
 - Hard (printed) copies of service manuals for regularly serviced machines (available at www.advance-us.com and other Nilfisk-Advance websites).
- These tools are also available from Nilfisk-Advance, Inc.:
- Vacuum water lift gauge, p/n 56205281

Focus II and Scrubtec R 6 Cylindrical, Disc, and Boost PM Checklist

Customer _____

Address _____

City _____ St _____ Zip _____

Model _____ Serial _____ Hours _____

Defect Codes

- A needs adjustment
- B binding
- C dirty or contaminated
- D damaged, bent or torn
- L leaks
- M missing
- W worn out

Ref	OPERATIONAL INSPECTION ITEMS	OK or N/A	Defect Codes (circle)	Does Not Work
1	Steering		A B	
2	Drive Pedal Operational (check for Fwd/Rev Drive & any neutral creep)		A B D	
3	Seat Switch		D	
4	Electrical Parking Brake (Brake releases when the key is turned on and the drive pedal is engaged. Brake engages when machine is at rest.)		A B W	
5	Drive System Performance (refer to Curtis Programmer Manual SM56043101 for speed control changes)		Noisy Sluggish	
6	Scrub System (Raise, Lower, auto scrubbing functions)		A B	
7	Scrub Brush (pressure settings Normal/Heavy/Extreme scrub)		A B	
8	Squeegee System (Raise, Lower, Auto-raise in reverse)		A B D	
9a	Vacuum Performance Single Motor (sealed water lift 63", 1-inch open hole aperture 10")		C L W	
9b	Vacuum Performance Dual Motor (sealed water lift 65", 1-inch open hole aperture 18")		C L W	
10	Solution Control (On/Off, Increase & Decrease for Normal/Heavy/Extreme)		A B L	
11	Emergency Stop Knob		B D	
12	Seat		A B D	
13	Optional Accessories		D	
14	Main Control Board Special Program Options and Fault Recall Mode– check all applicable program settings per Changing Program Settings section and examine stored fault codes.			
15	Battery Charger Programmed Correctly for Battery		A	
16	Battery Charger Operation		D	

Ref	VISUAL INSPECTION ITEMS	Comments	OK or N/A	Defect Codes (circle)	Does Not Work
17	Scrub Brushes (check for wear and rotate)			A B D W	
18	Scrub Brush Motor Carbon Brushes	Wear Limit 3/8"		B L W	
19	Scrub Brush Gimbals	In Brush Plates		W	
20	Auto Tension Belt – Wear and Tension (cylindrical)			A D W	
21	Spring Retainers	In Brush Plates		D	
22	Scrub Deck Skirt Position	Slight Flare		A B W	
23	Solution Solenoid Valve			C L	
24	Solution Tank, Delivery Hoses & Filter	Clean Filter Screen		C L	
25	Vacuum Motor Carbon Brushes	Wear Limit 3/8"		W	
26	Vacuum Motor Gaskets & Filters			L W	
27	Vacuum Float Ball & Cage Assembly	Clean Float		C M	
28	Recovery Lid Gasket			C D L	
29	Recovery Tank Drain Hose & Cap	Flush		C L	
30	Recovery Tank Strainer Basket	Clean		C D	
31	Squeegee Pick-Up Tool and Hose	Back Flush		C L	
32	Squeegee Blades (clean & rotate)			A C D W	
33	Squeegee Lift Actuator Motor & Cable			A B D	
34	Battery Condition (clean & water)	Load Test		C W	
35	Drive Wheel Motor Carbon Brushes	Wear Limit 1/4"		C W	
36	Drive Pedal Neutral Return			A C	
37	Steering Chain Lube & Tension	1/4" Deflection		A B C	
38	Steering Column Universal Joint			A D	
39	Rear Wheels			C	
40	Hopper (Cylindrical only)			C	

WORK COMPLETED BY:

ACKNOWLEDGED BY:

Service Technician Signature

Date

Customer Signature

Date

Chassis System

Functional Description

The chassis system consists of a tubular frame that provides the main substructure for the rest of the machine. To support the concentrated weight of the batteries, the battery box rests directly on the chassis. The solution tank bolts to the chassis to support the tank and make it more rigid.

The forward drive wheel is connect to the frame through a thrust bearing block for rotational movement. An integral (welded) rear axle through the frame transfers the load of the machine to the rear idler (non-driven) wheels.

The scrub deck lift actuator and linkages mounts to the underside of the frame. This assembly is not normally removed from the system during maintenance. Similarly, the squeegee lift mechanism mounts directly to the underside of the frame via ball joints that permit vertical and lateral movement.

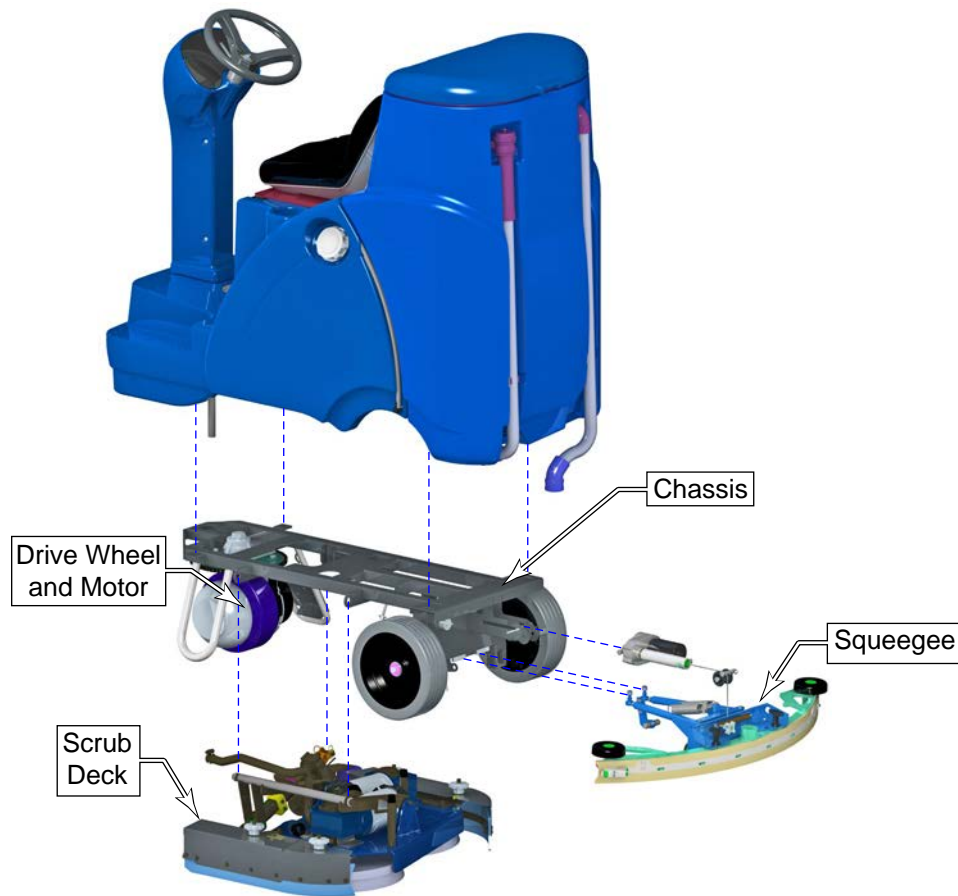

Control System

Functional Description

Within the Focus system there are two primary controllers: the Main Machine Controller (A1) and the Wheel Drive controller (A2). The Main Machine Controller controls the primary machine functions, and the Wheel controller controls the drive functions. The Wheel controller communicates with the Main Machine Controller to inform the Main Machine Controller of machine movement status.

Control Panel

The control panel (display) is an integral component with the Main Machine Controller (A1) circuit board.

Key Switch (A): The key switch serves as a main control switch to enable or disable operation of the machine. The key is removable to prevent unwanted operation when not in use. The key switch doesn't disconnect any power circuits, but instead, sends a signal to both the Main Machine Controller and Wheel Drive controller to indicate the On/Off function.

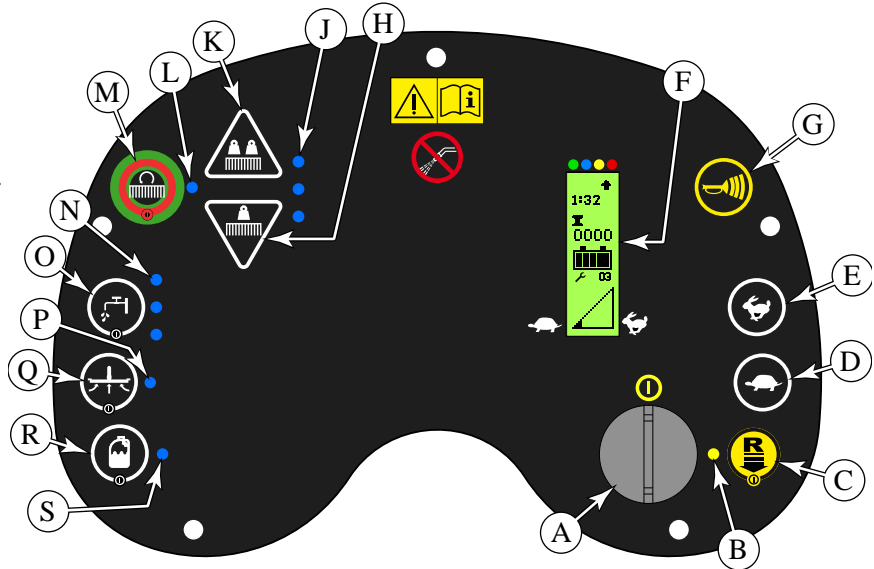

Reverse Switch (C) and Indicator

(B): The reverse switch activates a toggle function within the Main Machine Controller. The Main Machine Controller then sends a reverse command to the Wheel controller by pulling the (J3-3) output high. When the Indicator (B) is lit, pressing down on the foot pedal will cause the machine to move in reverse.

Speed Increase/Decrease Switches (D & E): These switches set the upper speed limit of the machine for the full throttle position. The machine speed limit is controlled within the Main Machine Controller, and the Main Machine Controller communicates this setting to the Wheel controller. For Wheel controllers, the speed limit function is typically controlled with a 3-wire potentiometer. The Main Machine Controller contains an electronically controlled potentiometer.

Graphic Display (F): Machine operation information is presented to the operator on the graphic display.

F1: Detergent Strength Indicator (for detergent systems only).

F2: Detergent Ratio (for detergent systems only).

F3: Hour meter (total use of the machine)

F4: Battery Indicator

F5: Fault Indicator

F6: Fault Code

F7: Speed Limit Indicator

F9: Battery Low Screen

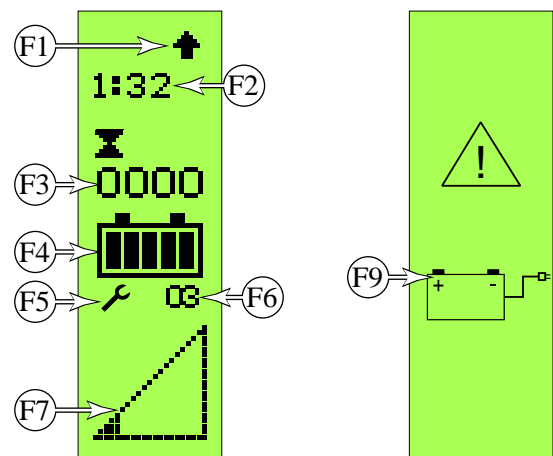

Horn Switch (G): Activates the horn

Scrub On/Off Switch (M): Pressing this switch will toggle the scrub system on and off. When active, the scrub deck will lower for the Deck Down Time. When the machine begins to move, the squeegee will lower

and the solution and vacuum systems will turn on. The brushes will turn on and the scrub deck will continue to lower until the expected motor amperage is reached.

Brush Pressure Increase and Decrease Switches (H & K): When scrub mode is active, pressing these switches will increase or decrease the scrub brush pressure. The three indicator LEDs (H) will illuminate to represent High, Medium, and Low pressure settings.

Solution Switch (O): The solution system will be active when the Scrub On/Off system is engaged. Pressing this switch will cycle through the solution rates (Normal, Medium, High, and Off). The solution flow will turn on only when the machine is in forward transport. The solution flow will turn off if the throttle returns to neutral or reverse transport is active. Pressing this switch when the scrub system is off will momentarily turn the solution flow on to allow pre-wetting of the scrub brushes.

Vacuum Switch (Q): The vacuum system will be automatically active when the Scrub system is active. This switch is used to toggle the vacuum system on or off independent of whether the scrub system is active or not.

Detergent Switch (R): The detergent injection system is an optional accessory. The detergent pump is active only when the solution pump is active. Pressing this switch will cycle through the detergent ratios.

Main Machine Controller

The Main Machine Controller (A1), which includes the control board and the display, is the primary electronic control for the Focus machine and its functions (except drive control). The control board is the basic input/output device and contains a micro-controller chip to regulate function. The controller receives and interprets user inputs, sensor inputs, and even some motor amperage readings, and controls device output for the user display, solenoid operation, and motor control. Most low and medium power outputs are controlled with power MOSFET transistors, and very high power devices (vacuum and brush motors) controlled with external motor contactors.

Another function of the Main Machine controller is to detect any system failures and display an error code on the display panel or store it in the main control board's memory. The error code(s) are used to help the service person determine the fault and to quickly guide in repairing a specific system malfunction. An additional special feature of the main control board is to change program settings for a set of specific machine functions. See the section, [Main Machine Controller Programming](#) described on page 19 for further information.

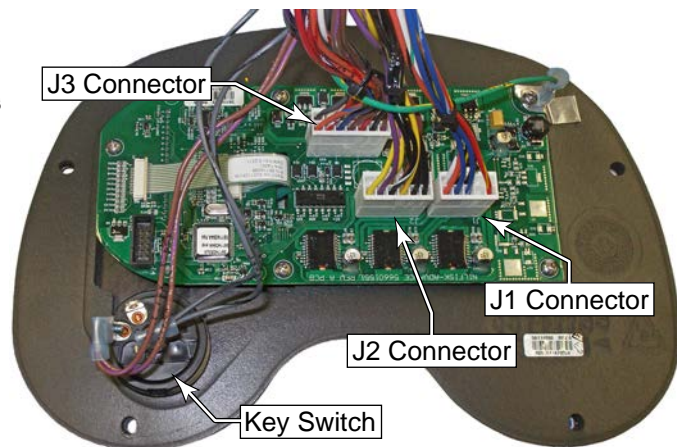

Component Locations

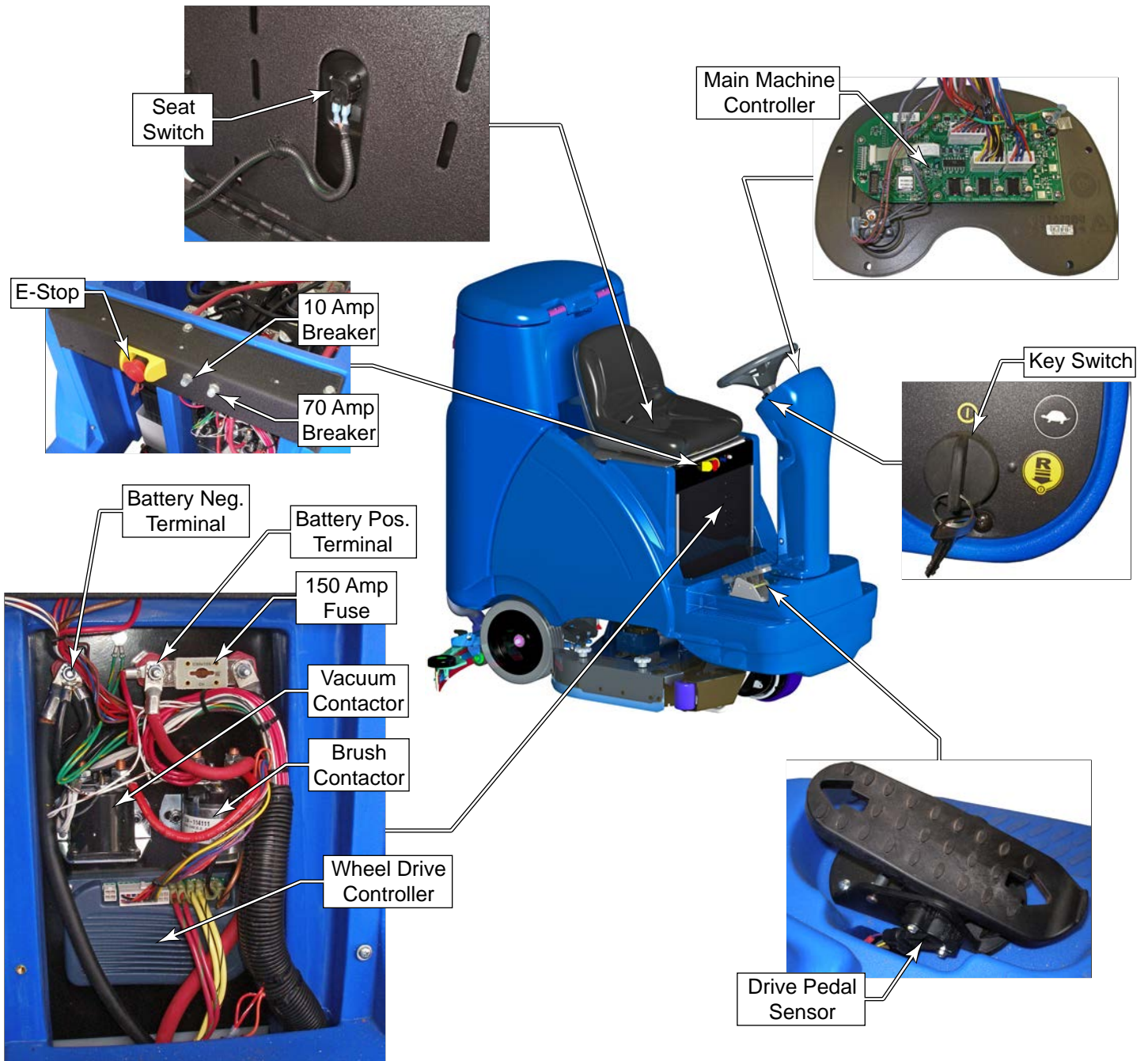

Main Machine Controller Programming

The Main Machine Controller is programmable for machine specific functions and parameters through a hidden menu system. This is a required task when replacing the controller with a new controller or changing features. The listings below and following sections describe the parameters to be programmed. Refer to [Navigating the Hidden Menus](#) on page 20.

Programming Menu Outline

- | | | |
|---|--|--|
| 1. Deck Type | <ul style="list-style-type: none"> • Main Free Battery 70%
LVC = 21.75V • Wet Battery 80%
LVC = 20.55V | 15. Fault Recall |
| <ul style="list-style-type: none"> • 28 Inch Boost • 40 Inch Disc • 34 Inch Disc / BR855 • 28 Inch Cyl / BR755C • 28 Inch Disc / BR755 | 7. Max Scrub Speed | <ul style="list-style-type: none"> • -- (none) |
| 2. Battery Charger | 8. Lockout Brush Pre (Pressure) | 16. Fault Detection |
| <ul style="list-style-type: none"> • AGM Fullriver 25A † • Wet 15A • Gel-AGM 25A • Gel Exide 25A • AGM Discover 25A • Wet 25A • None | <ul style="list-style-type: none"> • 1. None | <ul style="list-style-type: none"> • 1. Enabled • 2. Disabled |
| 3. Chemical Selection | 9. Lockout Sol Flows (Solution) | 17. Service Test Mode |
| <ul style="list-style-type: none"> • Onboard Chemical • No Onboard Chemical | <ul style="list-style-type: none"> • 1. None | <ul style="list-style-type: none"> • See Service Test Mode on page 22 |
| 4. Detergent Mode | 10. Recovery Tank Full | 18. Backup Alarm Vol (Volume) |
| <ul style="list-style-type: none"> • 1. Off | <ul style="list-style-type: none"> • 1. Disabled | <ul style="list-style-type: none"> • 4. High • 3. Medium • 2. Low • 1. Off |
| 5. Vacuum Selection | 11. Chemical Rate Bias | 19. FWD Alarm Vol (Forward) |
| <ul style="list-style-type: none"> • 2 Vacuum Motors • 1 Vacuum Motor | <ul style="list-style-type: none"> • 1. None | <ul style="list-style-type: none"> • 4. High • 3. Medium • 2. Low • 1. Off |
| 6. Low Voltage Cutout | 12. Deck Down Time | 20. Horn Volume |
| | <ul style="list-style-type: none"> • x.x Seconds
(1.0 to 5.0 in 0.1 increment) | <ul style="list-style-type: none"> • 4. High • 3. Medium • 2. Low • 1. Off |
| | 13. Restore Defaults | 21. Panel Test |
| | <ul style="list-style-type: none"> • 2. Yes • 1. No | |
| | 14. Display Rev Level | |
| | <ul style="list-style-type: none"> • Rev xx | |

† For North and South American (Clark) models equipped with Fullriver brand batteries only. Selecting this option on a Nilfisk-Alto model charger will result in that charger to operate with a “Gel-AGM-15A” mode.

Navigating the Hidden Menus

To enter the hidden menus, press and hold the Scrub (**M**) and Vacuum (**Q**) switches for 2 seconds while turning the key switch (**A**) to the On position. After 2 seconds, the display will show the first menu item, “1. Deck Type”, and you can release the switches.

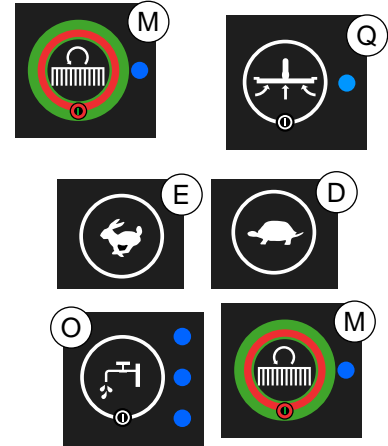

Use the Speed Increase (**E**) or Speed Decrease (**D**) switches to scroll through the menus and submenu options.

Use the Solution switch (**O**) to enter a submenu. Use the Scrub switch (**M**) to exit a submenu. The submenu option displayed on-exit will be saved to memory.

To save the changes and exit the hidden menus, turn the key switch to the off position.

To abort changes, turn the key switch (**A**) to the off position without exiting the submenu.

Deck Type

To ensure proper operation of the motor(s), the controller needs to know what type of deck is installed on the machine. The options are: 28” Boost, 40” Disk, 34” Disc, 28” Cyl., 28” Disc. This parameter must be set when replacing the Main Machine Controller.

Battery Charger

If no onboard charger is present or the Delta-Q IC650 is installed, this parameter must be set to “None”.

If the machine is equipped with the optional S.P.E onboard battery charger, then the controller needs to know the type of batteries installed in the machine. This information is communicated from the Main Machine controller to the S.P.E battery charger, so that it uses the correct charging profile for the batteries. If the installed batteries are rated for 150 amp-hour (or less) discharge, then a 15-amp charging rate must be selected.

Chemical (Detergent) Selection

The detergent selection menu is used to disable the detergent system or to set the display type for the detergent ratio.

- Onboard Chemical, activates the onboard detergent system.
- No Onboard Chemical, disables the onboard detergent system.

Detergent Mode

This function is not currently available.

- 1. Off

Vacuum Selection

The Focus machine may contain an optional second vacuum motor. It is important that this option be identified to the controller in order for the controller to properly monitor the amperage for one or two motors. If this option is not properly set, the Main Machine controller may report an over-current error.

- 1 Vacuum Motor
- 2 Vacuum Motors

Low Voltage Cutout

This option protects the batteries from being overly discharged. When the battery level reaches the low voltage cutout threshold, the scrub system will shut off. The value of the low voltage cutout is dependant on the type of battery being used, as described below.

- Main (Maintenance) Free Battery 70%
LVC = 21.75V
- Wet Battery 80%
LVC = 20.55V

Max (Maximum) Scrub Speed

This function is not currently implemented and maximum scrub speed is not limited (100% of transport speed).

- 100% of Transport

Lockout Brush Pre (Pressure)

This function is not currently implemented. Certain scrub pressures can be locked out so they are not selectable during normal operation. If two pressures are locked out, then the machine will operate with only the single remaining pressure available.

- 1. None

Lockout Sol (Solution) Flows

This function is not currently implemented. Certain solution rates can be locked out so they are not selectable during normal operation. If two rates are locked out, then the machine will operate with only the single remaining solution rate available.

- 1. None

Chemical (Detergent) Rate Bias

This function is not currently implemented. To ensure that the actual detergent rate is consistent with the user-selectable ratio, the rate can be biased up or down by 10%.

- 1. None

Deck Down Time

The initial lowering of the scrub deck is timed, because there will not be any brush motor amperage to monitor for determining when to stop lowering the deck. This is used by engineering during development. Under normal circumstances, this should not need to be changed.

- x.x Seconds
(1.0 to 5.0 in 0.1 increment)

Restore Defaults

Activating this setting will restore all of the memory settings to their factory default values. When the key switch is next turned on, the controller will enter program mode to set the deck type.

Display Rev Level

This entry displays the revision level of the software within the control board.

Fault Recall

This entry displays any fault codes stored in memory. Refer to [Main Controller Error Codes](#) described on page 23 for a list of error codes. If no fault exists, the display will show "--".

Fault Detection

This option will allow service personnel to override some of the fault detection checks to facilitate troubleshooting. If a fault occurs in a particular system, that system (and possibly others) will be shut down. This can make troubleshooting the system difficult. This will not disable the over-current protection on any of the systems. **Important:** Make sure to turn Fault Detection back on (Enable) before returning the machine to normal operation.

Service Test Mode

Service test mode provides access to all of the machine's motor and solenoid functions. This allows the technician to exercise the components for testing and troubleshooting. Refer to [Service Test Mode](#) described on page 25 in the Troubleshooting section for a description of the options. (**Note:** Exiting Service Test Mode requires turning off the key switch.)

Backup Alarm Vol (Volume)

Whenever the machine is moving in the reverse direction, the backup alarm can sound to notify bystanders that the machine is backing up. There are 4 options for the volume, including disabling the function (off, low, medium, and high).

FWD Alarm Vol (Forward)

Whenever the machine is moving in the forward direction, the forward alarm can sound to notify bystanders that the machine is moving forward. This may be beneficial if the machine is used in high traffic areas with many bystanders. There are 4 options for the volume, including disabling the function (off, low, medium, and high).

Horn Volume

The horn will sound when the horn switch is pressed. There are 4 options for the volume, including disabling the function (off, low, medium, and high).

Panel Test

This diagnostic function is used to test the lights and switches (buttons) of the machine display. When activated, all of the lights on the display will be illuminated. As each switch on the display is pressed, the LCD will display the name of the button, and a counter to indicate how many buttons have been pressed. To exit the Panel Test mode, the key switch must be turned to the off position.

Troubleshooting Guide

Any error codes detected by the main control board will be shown on the display panel as they occur. If more than one error exists the display will sequence through the error codes at one-second intervals. The error will display as a mechanical wrench symbol (**F5**) followed by a two-digit code (**F6**).

Main Controller Error Codes

Error	Description	Comments
03	Drive System Fault.	The Wheel Drive Controller is reporting an error. See the Wheel Drive Controller Error Codes described on page 82 for a list of error codes.
04	Scrub Deck Lift Actuator Overload.	The actuator amperage was detected above 6 amps for more than 5 seconds. <ul style="list-style-type: none"> Inspect the scrub deck for obstruction. Measure the actuator amperage with and without the scrub deck connected. <ul style="list-style-type: none"> Raising current = 1.4 to 2.8 amps Lowering current = 0.8 to 1.3 Amps If the no-load current remains high, then the actuator or wiring is faulty.
05	Brush Motor Overload	The brush motor amperage was detected above 60 amps for greater than 5 seconds. <ul style="list-style-type: none"> Check the scrub setting adjustments described previously in this chapter. Check for binding in rotation of brushes or improper deck lift actuator operation. Inspect the ground wire supplying the brush motors for poor or corroded connections. The voltage drop across this wire is used to measure the amperage to the motors. Inspect the current sense wire (Yellow/violet) for continuity. Make sure the correct scrub deck is specified in the control board settings.
06	Squeegee Lift Actuator Overload	The actuator amperage was detected above 6 amps for more than 5 seconds. <ul style="list-style-type: none"> Check the Actuator Limit Adjustment described on page 73. Inspect the actuator and cable for obstructions to movement. Measure the actuator amperage: <ul style="list-style-type: none"> Raising current = 2.2 to 3.4 amps Lowering current = 2.2 to 2.6 Amps
07	Vacuum Motor Overload	The motor amperage was detected above 25 amps for more than 5 seconds for each motor (Normal current load is 18-20 Amps per motor.). <ul style="list-style-type: none"> If the optional second vacuum motor is installed, enter the main machine controller programming and ensure that the Vacuum Selection is set for 2 vacuum motors. Inspect the vacuum motor impeller for obstruction. Check the vacuum discharge for obstruction (inlet obstruction will reduce the amperage). Inspect the vacuum motor brushes Defective motor bearings. Inspect the current sense wire (Brown/Red) for continuity
08	Solution Solenoid Overload	The solenoid amperage was detected above 2.4 amps for more than 5 seconds. <ul style="list-style-type: none"> Check for wiring problems on the coil circuit and repair wiring. Check resistance on the solenoid coil. If the value is less than 20% of the values below, replace the contactor/solenoid <ul style="list-style-type: none"> Solution solenoid coil (L1): 33.5 Ω

Error	Description	Comments
09	Vacuum Contactor Coil Overload	<p>The contactor coil amperage was detected above 2.4 amps for more than 5 seconds.</p> <ul style="list-style-type: none"> • Check for wiring problems on the coil circuit and repair wiring. • Check resistance on the contactor coil. If the value is less than 50 Ω, replace the contactor.
10	Brush Contactor Coil Overload	<p>The contactor coil amperage was detected above 2.4 amps for more than 5 seconds.</p> <ul style="list-style-type: none"> • Check for wiring problems on the coil circuit and repair wiring. • Check resistance on the solenoid coil. If the value is less than 45 Ω, replace the contactor.
11	Chemical Pump Overload	<p>The pump coil amperage was detected above 2.4 amps for more than 5 seconds.</p> <ul style="list-style-type: none"> • Check for wiring problems on the motor circuit and repair wiring. • If the actual current through the pump is high, replace the pump. It is a solenoid driven diaphragm pump and a fluid blockage will not increase amperage.
70	Corrupt Communication From On-Board Battery Charger	<p>The Battery Charger did not properly repeat the charging profile message back to the Main Machine Controller.</p>

Service Test Mode

To assist in the troubleshooting and servicing of the electrical system and related components, a special test mode allows independent control of the various outputs and monitoring of the various inputs. To enter the service test mode perform the following steps:

1. To enter the hidden menus, press and hold the Scrub (M) and Vacuum (Q) switches for 2 seconds while turning the key switch (A) to the On position. After 2 seconds, the display will show the first menu item, “1. Deck Type”, and you can release the switches.
2. Use the Speed Increase (E) or Speed Decrease (D) switches to scroll through the menus until you reach “17. Service Test Mode”.
3. Use the Solution switch (O) to enter the Service Test Mode submenu.
4. To exit Service Test Mode, turn the key switch to the off position.

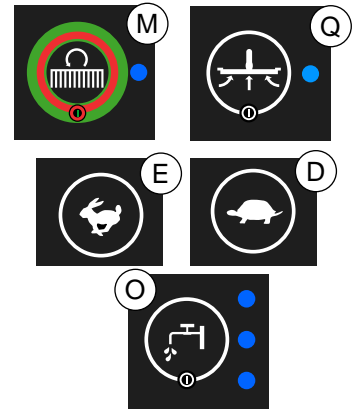

Test Mode Display

In Service Test Mode, the display will present basic information about the machine. The battery voltage, as determined by the control board, is shown at (F10). A listing of current error codes is shown at (F11). If there are several codes, up to 8 will be displayed in this space. The remainder of the display area (F12) shows device status. (SPD=Drive, SOL=Solution Solenoid, VAC=Vacuum Motor, DECK=Deck Lift Actuator, SQG= Squeegee Lift Actuator, BR=Brush Motor, CP=Detergent (chemical) Pump)

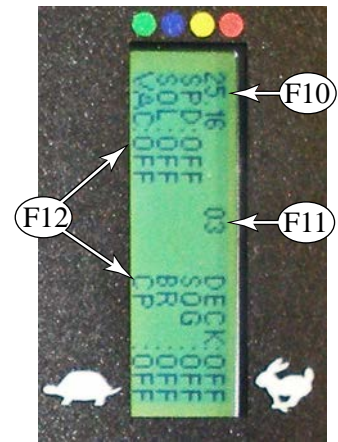

Test Mode Functions

The other primary aspect of Service Test Mode is to exercise motors and solenoids. The switches necessary to access these functions are listed below.

Function	Switch	Function	Switch
Operate the Detergent Pump		Lower the Scrub Deck	
Operate the Vacuum Motor		Raise the Scrub Deck	
Operate the Solution Solenoid		Cycle the Squeegee Lift	
Operate the Brush Motor(s)			

Sample Shop Voltage Measurements

Examining signals sent and received at the control board can be very effective in determining if external components are functioning as expected or if the control board is processing them as expected. The tables below show sample voltage measurements taken from a Focus machine. Actual voltages will vary from machine to machine, and with battery charge level.

The majority of voltage measurements will be dependant on the battery voltage of the machine at the time. The nominal battery voltage is 24 volts, but depending on the charge state of the battery, the actual voltage may be higher or lower. With regard to digital logic signals, the terms “High (voltage)” and “Low (voltage)” mean a voltage value equal (or close to) Battery-Positive and Battery-Negative, respectively. V_{CC} is a special voltage value that is independent of the battery voltage, and is regulated to be close to 5.0 volts by the Main Machine Controller’s circuit board.

Some signals are Pulse-Width Modulated (PWM) This means that these signals are being turned On and Off at a high rate. Even though their instantaneous voltage jumps from 24V to 0V, your voltmeter will average these On/Off jumps into an equivalent voltage somewhere in between 24 and 0 volts. The “≈” symbol means “approximately”.

To aid in taking voltage measurements from the cable connectors without removing the connector, a T-shaped push pin connected to the voltmeter probe wire works well (see image to the right).

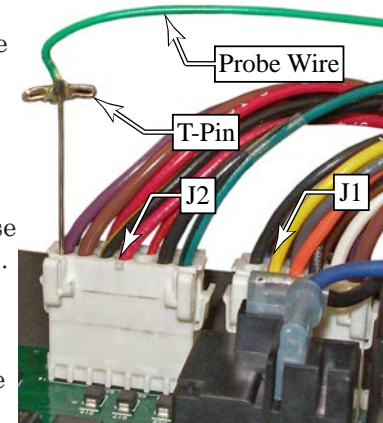

Main Machine Controller Sample Voltage Measurements at the J1 Connector					
Pin #	Name	V-On	V-Off	Ref.	Comments
J1-1	Det Pmp+	≈8	2.16	B-	PWM output to detergent pump between J1-1 and J1-3
		≈5	0	J1-3	
J1-2	Not Used				
J1-3	Det Pmp+	≈8	2.16	B-	PWM output to detergent pump between J1-1 and J1-3
		≈5	0	J1-1	
J1-4	Deck Lift+ (Raise)	0.2	2.2	B-	Differential output for the deck actuator. When inactive, the difference between J1-4 and J1-5 is zero. When active, the difference between J1-4 and J1-5 is just below battery voltage, and reverses polarity depending on the direction.
	Deck Lift+ (Lower)	24.3	2.2	B-	
J1-5	Deck Lift- (Raise)	24.3	2.2	B-	
	Deck Lift- (Lower)	0.2	2.2	B-	
J1-6	Not Used				
J1-7	Not Used				
J1-8	B-	0.06	0	B-	Voltage drop should remain low for all functions
J1-9	Sq Lift+ (Raise)	0.3	2.2	B-	Differential output for the squeegee lift actuator. When inactive, the difference between J1-4 and J1-5 is zero. When active, the difference between J1-4 and J1-5 is just below battery voltage, and reverses polarity depending on the direction.
	Sq Lift+ (Lower)	23.9	2.2	B-	
J1-10	Sq Lift- (Raise)	23.9	2.2	B-	
	Sq Lift- (Lower)	0.3	2.2	B-	

Main Machine Controller Sample Voltage Measurements at the J2 Connector					
Pin #	Name	V-On	V-Off	Ref.	Comments
J2-1	B-	0.06	0	B-	Voltage drop should remain low for all functions
J2-2	B-	0.06	0	B-	Voltage drop should remain low for all functions
J2-3	Ch Comm	Data	0.8	B-	Communication channel with the S.P.E. battery charger. The voltage will fluctuate as the data stream changes content.
J2-4	Sp Pot Out	†	N/A	B-	Resistive functions from an on-board electronically controlled resistor circuit. These values are used by the Wheel Drive controller. † 4Bar = 4.5, 3Bar = 3.4, 2Bar = 2.8, 1Bar = 2.3
J2-5	Sp Pot Lo	0.42	N/A	B-	
J2-6	Sp Pot Hi	4.54	N/A	B-	
J2-7	B-	0.06	0	B-	Voltage drop should remain low for all functions
J2-8	B-	0.06	0	B-	Voltage drop should remain low for all functions
J2-9	1Vac Amps 2Vac Amps	0.12 0.23	0.0	B-	Input for the vacuum motor amperage. Uses voltage drop across the ground wire to determine the amperage. Approximately 4.1 mV per amp.
J2-10	Brush Amps	0.126†	0.0	J1-5	Input for the brush motor amperage. Uses voltage drop across the ground wire to determine the amperage. († 3 motors, no load) Approximately 2.3 to 3.4 mV per amp.
J2-11	Deck Pos 2	0	4.94		Scrub deck position switches inside actuator. Close (0 volts) when deck lowers to each position. Open (5 volts) when raised.
J2-12	Deck Pos 1	0	4.94		

Main Machine Controller Sample Voltage Measurements at the J3 Connector					
Pin #	Name	V-On	V-Off	Ref.	Comments
J3-1	B+	25.6	25.6	B-	
J3-2	B-	0.06	0	B-	Voltage drop should remain low for all functions
J3-3	Rev Out	23.8	0	B-	Signal to the drive controller to indicate that reverse is active.
J3-4	Seat Sw	25.1	0	B-	Input from the mechanical switch under the seat (also in series with E-Stop switch)
J3-5	Rev In	1.6	25.1	B-	Input from drive controller to signal machine in motion in reverse
J3-6	Motion In	0.25	23.1	B-	Input from drive controller to signal machine in motion either direction
J3-7	Drv Status	Data	1.2	B-	Input from the drive controller for status. (Sequence of 24V pulses)
J3-8	B+	25.6	25.6	B-	
J3-9	Horn-	Var Freq	13.2	B-	Horn+ comes from 15 V voltage regulator. Horn- is switched to 0V at high frequency PWM.
J3-10	Horn+	14.9	14.9	B-	
J3-11	Solution Sol	0.21	25.1	B-	Low speed PWM control of the solution solenoid.
J3-12	Vac Cont	0.1†5.0	25.1	B-	PWM control of the vacuum motor contactor. The signal starts at full duty cycle to pull the contacts closed, and then reduces the duty cycle to hold them closed to minimize the load on the coil.
J3-13	Brush Cont	0.1†5.0	25.1	B-	PWM control of the brush motor contactor. The signal starts at full duty cycle to pull the contacts closed, and then reduces the duty cycle to hold them closed to minimize the load on the coil.
J3-14	Key Switch	25.1	0	B-	

Controller I/O Table

Designation	Pin	Type	Nominal	Ref.	Range	Comments
Det. Pump (+)	J1-1	PWM	24 V	B-	20-26V	-24V in FWD, +24V in REV
Not Used	J1-2					
Det. Pump (-)	J1-3	PWM	-24 V	B+	20-26V	-24V in FWD, +24V in REV
Brush Act. (+)	J1-4	DC Voltage	24 V	B-	20-26V	+24V in FWD, -24V in REV
Brush Act. (-)	J1-5	DC Voltage	-24 V	B+	20-26V	-24V in FWD, +24V in REV
Not Used	J1-6					
Not Used	J1-7					
Battery -	J1-8					
Squeegee Act. (-)	J1-9	DC Voltage	-24 V	B+	20-26V	-24V in FWD, +24V in REV
Squeegee Act. (+)	J1-10	DC Voltage	24 V	B-	20-26V	+24V in FWD, -24V in REV
Ground	J2-1	DC voltage	24 V	B+	20-26	DC voltage
Ground	J2-2	DC voltage	24 V	B+	20-26	DC voltage
Charger Comm	J2-3	Digital	0-5	B-	0 - 5	Communication with charger
Spd Pot Output	J2-4	Analog	0-5	B-	0 - 5	Analog output
Spd Pot Low	J2-5	DC voltage	0	B-	0	Digital input
Spd Pot High	J2-6	Ground	5	B-	5	Digital input
Ground	J2-7	DC voltage	24 V	B+	20-26	DC voltage
Ground	J2-8	DC voltage	24 V	B+	20-26	DC voltage
Vacuum Current	J2-9	Voltage Drop	1) 88 mV 2) 176 mV	B-		Voltage drop 4.1mV per amp, Single vac tank full = 74 mV Dual vac tank full = 148mV
Brush Current	J2-10	Voltage Drop	130 mV	B-		Voltage drop 1.74 mV per amp
Position 2 Switch	J2-11	Switch		B-		Normally Open
Position 1 Switch	J2-12	Switch		B-		Normally Open
Power	J3-1	DC voltage	24 V	B-	20-26	DC voltage
Ground	J3-2	DC voltage	24 V	B+	20-26	DC voltage
Reverse_out	J3-3	DC Voltage	24V	B-	0-24V	Reverse signal to speed controller
Seat Switch	J3-4	DC Voltage	24 V	B-	20 -26	Digital input
Reverse Signal	J3-5	DC Voltage	24 V	B-		Forward is Low (1 to 0V), Reverse is High (20 to 26 V)
Fwd/Rev Signal	J3-6	DC Voltage	24 V	B-		Neutral is Low (1 to 0V), Moving is High (20 to 26 V)
Drive Status	J3-7	DC Voltage	24 V	B-		Pulsed signal equal to the fault code
Power	J3-8	DC voltage	24 V	B-	20-26	DC voltage
Horn-	J3-9	DC Voltage	15V	B-	0-15V	
Horn+	J3-10	DC Voltage	15V	B-	0-15V	
Solution Solenoid1	J3-11	DC Voltage	24 V	B-	20-26V	(Solenoid voltage is pulsed between 24V and 0V at a rate of about 1 Hz)
Vac Contactor	J3-12	PWM	24 V	B-	18-24V	(5KHz, 80% duty cycle)
Brush Contactor	J3-13	PWM	24 V	B-	18-24V	(5KHz, 80% duty cycle)
Key Switch	J3-14	DC Voltage	24 V	B-	20 -26	Digital input

Removal and Installation

Main Control Board

The main control board and the operator's display are integral components to one another and cannot be separated.



Caution! The main power connection to the control board is unswitched. Make sure to disconnect the battery connector to avoid damaging the control board.

1. If this procedure is being performed to replace a defective control board, and if that control board is functional enough to do so, enter the [Main Machine Controller Programming](#) menu described on page 19 and record the existing program parameters.
2. Turn off the key switch and disconnect the battery cable connector.
3. Remove the 5 screws (1) that secure the control board to the steering column.
4. Lift the control board away from the steering column, taking care not to stress the wiring harness.



5. Remove the two screws (2) that secure the two wires (3 & 4) to the key switch terminals.
 - During replacement, take care not to install the battery power (3) to the normally closed terminal (5). This terminal should not be used.
6. Remove the screw (6) that secures the ground wire (7) to the control board, and remove the wire.
7. Disconnect the cable connectors (J1, J2, & J3) from the control board.
8. Remove the control board.
9. After replacing the control board with a new one, the controller will automatically enter the hidden menu system when the key switch is turned on. The deck type for the machine must be set before the machine will operate.
10. Continue navigating through the [Main Machine Controller Programming](#) menu described on page 19 and restore all of the appropriate settings.

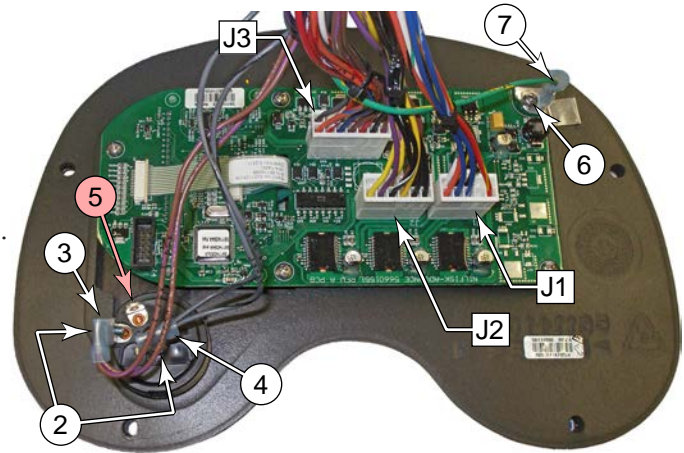

Electrical System

Functional Description

The Focus II machine is powered using four, 6-volt batteries connected in series, for a total system nominal voltage of 24 volts. To protect the batteries from over discharge, the system is protected with a 150 amp fuse (F1). With the exception of the optional on-board battery charger, all other connections are downstream from this main fuse.

There are 2 resettable circuit breakers that protect the electronics. A 70 amp circuit breaker (CB1) protects the Wheel Drive Controller (A2). A 10 amp circuit breaker (CB2) protects the Main Machine Controller. The brush contactor coil, vacuum contactor coil, and solution solenoid are also downstream from this circuit breaker. If these circuit breakers trip, their respective button will pop up. Pressing the button back in after the overload has cleared will reset the breaker.

Safety Circuit

A series of switches acts as a safety circuit to prevent certain machine operations under different conditions. The easiest way to describe their function is from last to first, because each upstream switch does the same thing as all downstream switches, but removes slightly more functionality.

The last of these is the seat switch. When the seat switch is open (no operator on seat), then control power is removed from the Wheel Drive controller. The Main Machine controller still has power, but the software is notified that the seat circuit (or E-stop) is open. The E-stop is similar to the seat switch, except it also disables power to several key components, such as the brush and vacuum contactor coils, the solution solenoid, and the optional flashing light. When an optional onboard battery charger is present, its internal interlock switch disables the same components as the E-stop, and opens the circuit whenever the charger is operating (plugged in to power).

The first switch in the circuit is the main key switch. It disables the same functions as all other switches downstream from it, but also disables most of the control power to the Main Machine controller too. The Main Machine controller always has some power (unless the batteries are disconnected).

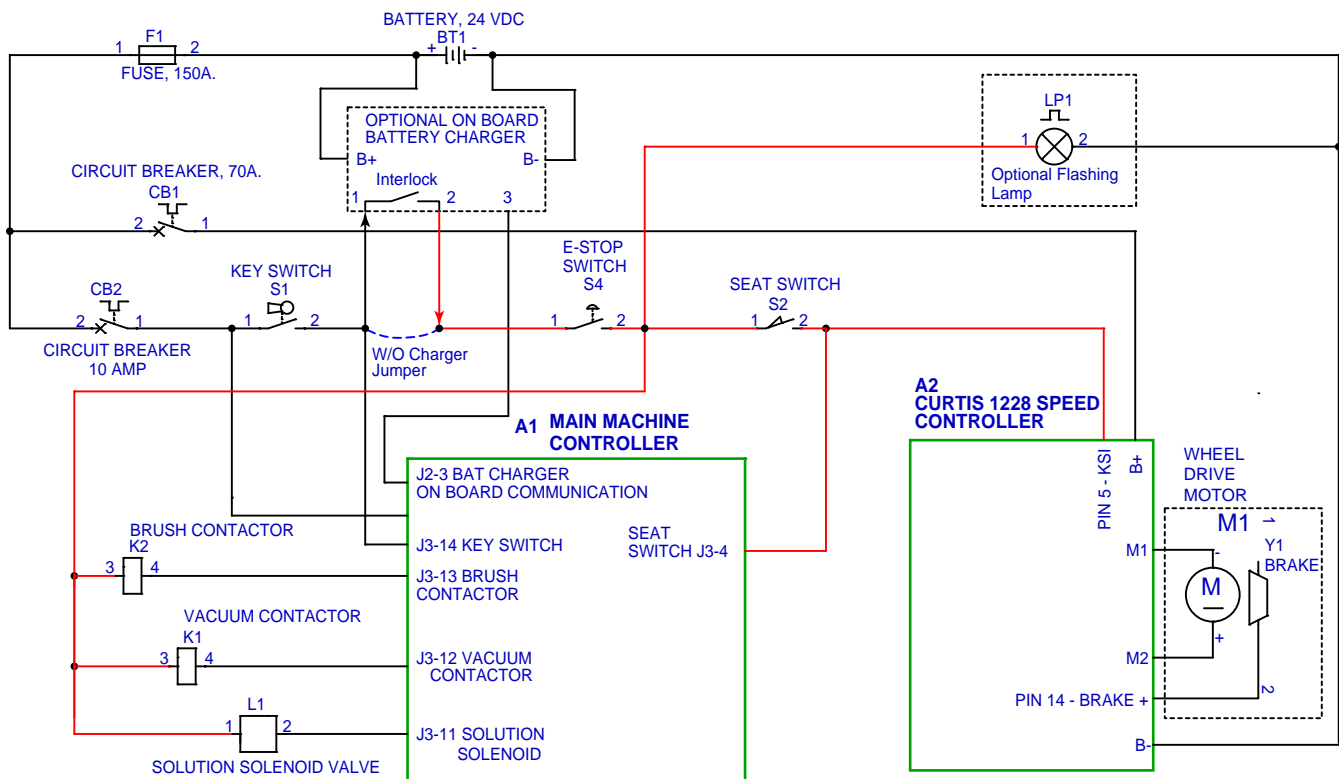

Description Of The Low-Voltage Cutout Feature

The Focus machine is equipped with a low-voltage cutout feature to prevent over-discharging of the batteries. When the machine's battery voltage falls below the defined threshold, the scrub system is automatically shut down to preserve battery power until the machine can be recharged. The voltage cutout level is adjustable for different battery types, because different battery types can sustain different levels of discharge without degradation. (Refer to the section, [Low Voltage Cutout](#) described on page 21).

Onboard Battery Chargers

An optional S.P.E battery charger or Delta_Q IC650 charger may be installed on the machine. Early machines used the S.P.E charger and later machines use the Delta-Q charger. Early machines may also be retrofitted to accept the Delta-Q charger.



Figure 1. Delta-Q Charger

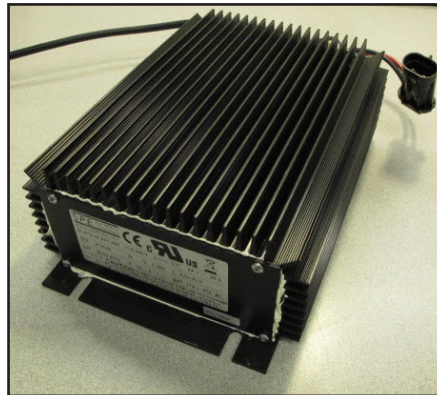

Figure 2. S.P.E. Charger

Interlock Circuit

Both types of battery chargers have an “interlock circuit” which consists of an internal relay that interrupts power to the drive wheel speed controller when the charger is plugged into an AC power outlet. This prevents the machine from being propelled while the batteries are charging.

S.P.E. Charging Profiles and Charging Progress

When the S.P.E. battery charger is plugged in, the graphic display will show the charging profile in use, and a battery icon with 0 to 5 bars to show the charging progress.



The S.P.E. battery charger and A1 Control Board communicate with one another on a wire that runs between them. Each time the battery charger is plugged in, the charger contacts the Controller by sending out a positive voltage on the communication wire to find out what kind of batteries are in the machine. It needs to know this in order to use the correct charging profile. The Controller responds and provides the battery type information it has stored in memory. The charger then tells the Controller which charging profile it will use and begins charging the batteries.

Refer to the [Control System, Main Machine Controller Programming Options](#) section for information on how to tell the controller what kind of batteries are used in the machine. If the charger is unable to communicate with the controller it will use the profile for a wet battery at a 25-amp rate as a default.

Delta-Q Charging Profiles and Charging Progress

The Delta-Q battery charger does not communicate with the main machine controller. It is a “stand-alone” unit. Models that have the Delta-Q charger have a separate LED to communicate charging progress. By pressing a button on the charger you can see what charging profile is in use. If you replace the batteries with a different type of battery or replace the battery charger, you must select the correct charging profile to be compatible with the batteries. There are a set of profiles stored inside the charger. You can interface directly with the charger to select the profile to be used from that set. See the Delta-Q IC650 Product Manual (710-0138-Delta-Q.pdf) for complete instructions on selecting the profile. Use the Delta-Q Battery Charging Profile Table below to choose the profile to match the batteries that are in the machine.

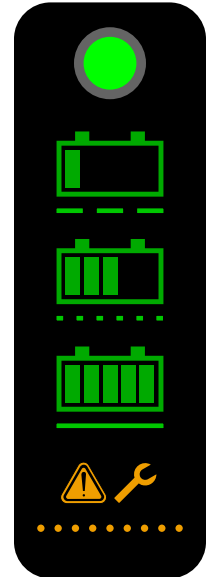

Delta-Q Battery Charging Profile Table

Battery Manufacturer	Volts	Battery Model #	20 Hour Rating	N-A P/N	Use Profile
DISCOVER	6	EV250A-AGM	260	40953A	P-0-4-3
DISCOVER	6	EV305A-A	312	56112546	P-0-4-3
DISCOVER	6	EV305A-A	312	56315959	P-0-4-3
DISCOVER	6	EV305A-AGM	312	40964A	P-0-4-3
DISCOVER	6	EVGT6A	255	56112545	P-0-4-3
DISCOVER	6	EVGT6A	255	56315772	P-0-4-3
DISCOVER	6	EVL 16A-A	390	56388582	P-0-4-3
DISCOVER	12	EV12A-A	140	56380239	P-0-4-2
DISCOVER	12	EV185A- A	234	56393912	P-0-4-3
DISCOVER	12	EV185A-A	234	41023A	P-0-4-3
EAST PENN MFG. CO.	6	8GGC 2/T881 (GEL CELL)	180	56206987	P-0-2-6
EAST PENN MFG. CO.	12	8G27MM/T876	86.4	56206988	P-0-2-6
FULL RIVER	6	DC 250-6	250	56112545	P-1-5-1
FULL RIVER	6	DC 335-6	335	56112546	P-1-4-1
TROJAN	6	J -305G	285	56391391	P-0-0-7
TROJAN	6	J-250-2992-41	250	56026200	P-0-0-3
TROJAN	6	L16-5592-41	395	56388582	NOT RECOMMENDED
TROJAN	6	T-125LPT	235	56206079	P-0-0-3
TROJAN	6	T-605LPT	195	56206117	P-0-0-3
TROJAN	12	J185-2292-42	195	56206078	P-0-0-3
US BATTERY	6	L16	375	40602A	P-0-7-3
US BATTERY	6	L16	375	40704A	P-0-7-3
US BATTERY	6	L16HC	415	56388582	P-0-7-3
US BATTERY	6	US-125	235	331318	P-0-1-1
US BATTERY	6	US-125	235	881317	P-0-1-1

Battery Manufacturer	Volts	Battery Model #	20 Hour Rating	N-A P/N	Use Profile
US BATTERY	6	US-125	235	56206079	P-0-1-1
US BATTERY	6	US-125	235	40136A	P-0-1-1
US BATTERY	6	US-125	235	40136B	P-0-1-1
US BATTERY	6	US-14 5XC	251	56317154	P-0-7-2
US BATTERY	6	US1800	201	56206117	P-0-1-1
US BATTERY	6	US250HC	275	56026200	P-0-1-1
US BATTERY	6	US-305	305	891384	P-0-7-2
US BATTERY	6	US-305	305	891385	P-0-7-2
US BATTERY	6	US-305	305	56391391	P-0-7-2
US BATTERY	12	UB27	86	40070A	P-0-0-6
US BATTERY	12	US-185	195	871334	P-0-1-1
US BATTERY	12	US-185	195	871335	P-0-1-1
US BATTERY	12	US-185	195	56206078	P-0-1-1
US BATTERY	12	US-31TMX	130	40605A	P-0-7-1
US BATTERY	12	US-31TMX	130	40606A	P-0-7-1

Component Locations

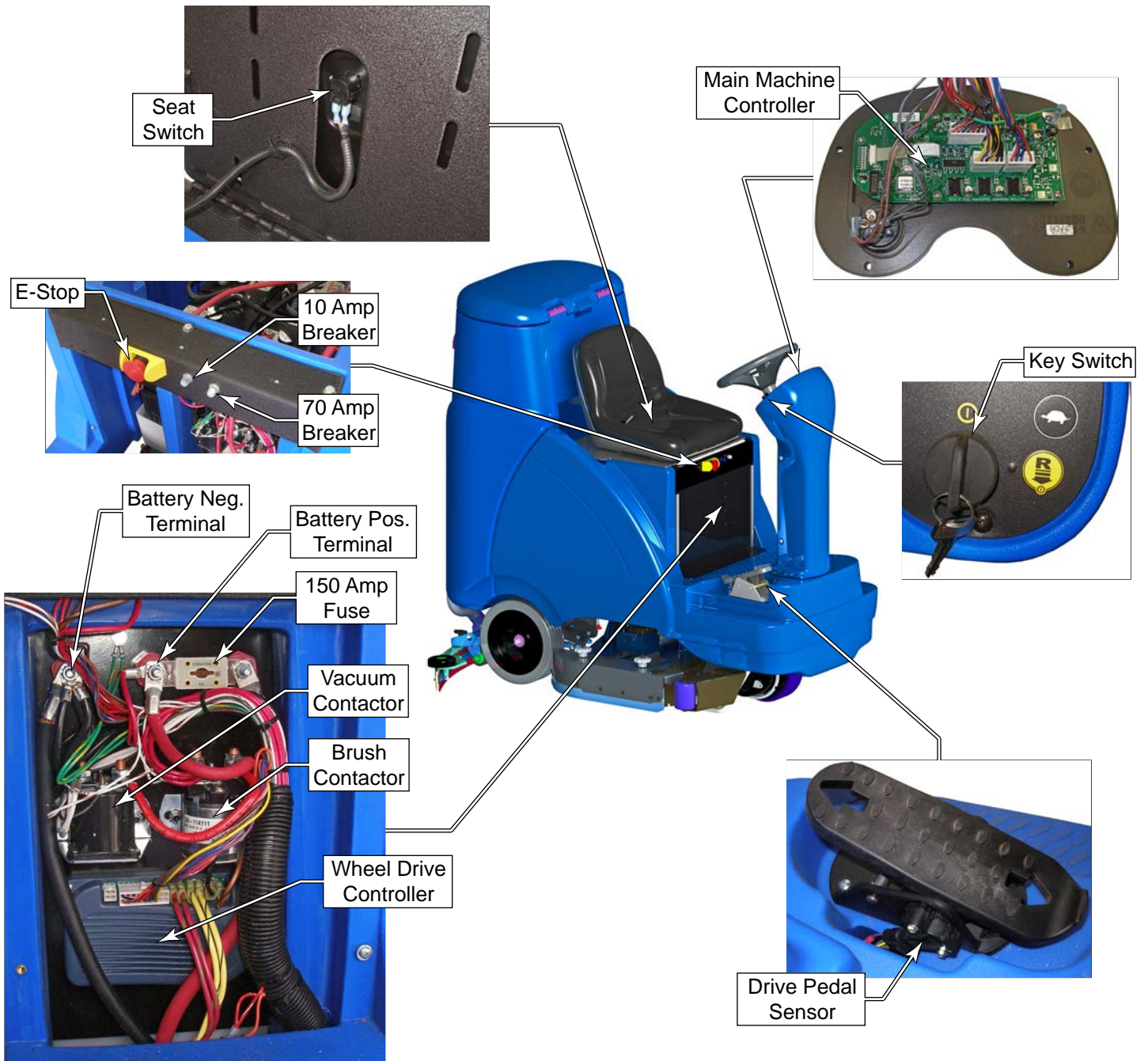

Maintenance and Adjustments

Charging Batteries



Caution!

- **Charge batteries in a well-ventilated area.**
- **Do not smoke while servicing the batteries.**
- **Remove all jewelry**
- **Wear safety glasses, rubber gloves and a rubber apron**
- **Do not allow tools to touch more than one battery terminal at a time**
- **To avoid damage to floor surfaces, wipe water and acid from the top of the batteries after charging.**

If your machine shipped with an onboard battery charger, turn the Key Switch off. Unwind the electrical cord from the side of the onboard charger and plug it into a properly grounded outlet. Confirm that the correct charging profile is in use. Refer to the OEM product manual for more detailed operating instructions.

If your machine uses an external battery charger, unplug the battery connector (1) from the machine connector (2), and plug the battery connector (1) into the charger. Follow the instructions on the battery charger.

Extending Battery Life

Proper maintenance of electric vehicle batteries can greatly extend their life. The following information will help extend the life of your batteries.

- Your battery will deliver superior performance and life if it is recharged properly. Excessive charging or discharging will shorten battery life and limit performance. Be sure to follow proper charging instructions.
- Make sure you have an appropriate charger for the type of battery. Use only “voltage-regulated” or “voltage-limited” chargers. Standard constant-current or taper current chargers must not be used. A temperature-sensing charger is recommended.
- **Important!** Do not attempt to open sealed gel batteries or add water. Doing so will damage the battery and void the warranty.
- For wet batteries, maintain proper electrolyte level and check weekly. Use distilled water in batteries whenever possible. If the batteries are discharged, add just enough water to cover the plates in each cell, and recheck the level after charging (this prevents over-filling the battery). If batteries are fully charged, fill each cell to the bottom of the filler tube. Do not over-fill the batteries! Do not add acid to batteries!
- Keep the batteries charged. Batteries should be charged each time that a machine is used for more than 1 hour. Machine operators should open the battery compartment cover for charging, to avoid a concentrated build-up of hydrogen gas. Operators should follow the instructions provided with their specific battery charger, to determine how long the batteries should be charged. Even when a machine is stored, the batteries should be charged once a month to prevent the batteries from “sulfating”. Most battery caps are vented, so there’s no need to loosen or remove them for charging.
- Keep the batteries clean. Use a damp cloth to wipe dirt from the top of the batteries. Battery terminals must be clean and tight. If the tops of the batteries are wet after charging, the batteries have probably been overfilled or over-charged. **Note:** If there is acid on the batteries, wash the tops of the batteries with a solution of baking soda and water (2 tablespoons of baking soda to 1 quart of water).

Troubleshooting

Battery Testing

A battery problem is usually recognized by the machine operator as a decrease in the machine's running time. This condition is usually caused by one or more "dead cells" in the battery system. There are 2 ways to find a dead cell:

- Use a hydrometer to check the specific gravity (or "state of charge") of the fluid in each cell. A dead cell is one that reads 50 points (or more) lower than the other cells.
- Use a volt meter to check the voltage of each battery. Look for a battery with a voltage that is 1 or 2 volts less than the other batteries. Check under the following conditions:
 - With the batteries fully charged,
 - With the scrub and drive motors running,
 - With the batteries discharged, but still above the voltage cutoff threshold.

If the batteries in the machine are more than 1 year old, it's usually best to replace the whole set, rather than replacing one or two batteries. Mixing old and new batteries can result in over-charging problems.

Removal and Installation

Batteries



Caution!

- Use extreme caution when working with batteries. Sulfuric acid in batteries can cause severe injury if allowed to contact the skin or eyes.
- Explosive hydrogen gas is vented from the batteries through openings in the battery caps. Do not smoke while servicing the batteries.
- Remove all jewelry. Wear safety glasses, rubber gloves and a rubber apron
- Do not allow tools to touch more than one battery terminal at a time
- Electrical components in this machine can be severely damaged if the batteries are not installed and connected properly.

1. Turn the Key Switch to the off position and disconnect the main battery connector (1).
2. Disconnect the vacuum motor connector and remove the [Recovery Tank](#) described on page 52.
3. Remove the cables from the batteries, and remove the batteries. Make note of the battery polarity and cable locations.
4. Install the new batteries into the compartment. Note the orientation of the batteries shown to the right. Not all of the batteries are oriented the same way.



Caution!

If you change the type of batteries (Wet VS Gel), you must change the charging profile used by the battery charger to be compatible with the new type of batteries.

5. Put a rubber boot over each end of the battery cables.
6. Connect the battery cables.
 - All cables are connected positive-to-negative for a series connection between all 4 batteries.

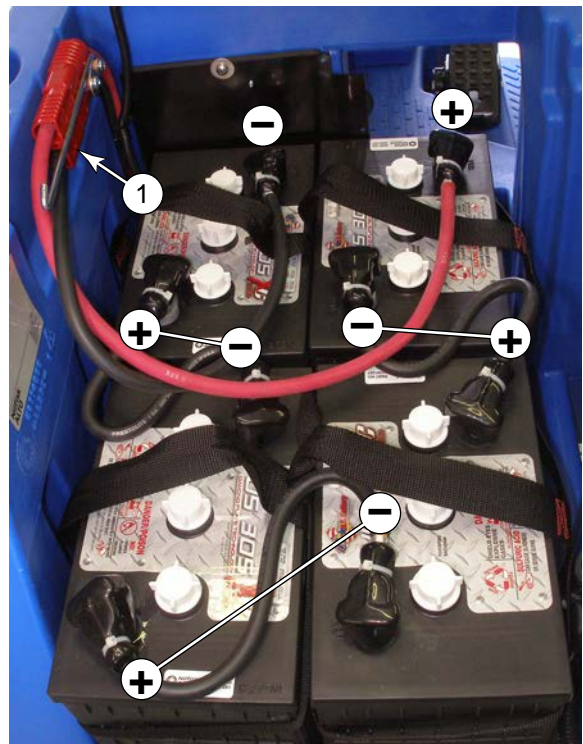

- Position the cables so the battery caps can be easily removed for battery service.
 - Take care to not over torque the cable connector, as this may damage the battery post.
7. Coat the terminals with spray-on battery terminal coating (available at most auto parts stores).

Electrical Panel Cover

This is a prerequisite procedure for completing other procedures that require access to the electrical panel.

1. Turn off the key switch and disconnect the main battery connector (1).
2. Remove the two screws (3) and washers (4) that secure the panel cover, and remove the cover.

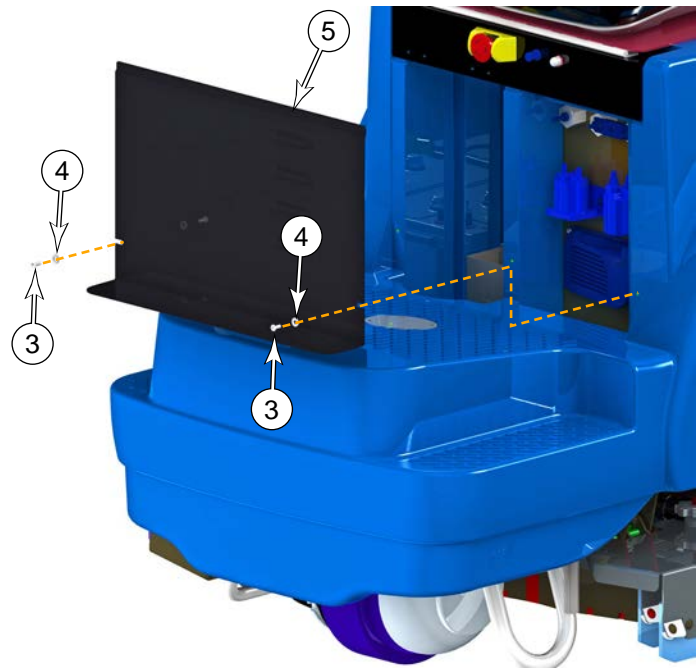

Specifications

Wet Cell Battery Specifications:

- Use a combination of multiple 6-volt units to construct a 24 Volt DC battery pack system.
- Advance recommended battery pack capacity is a 305 AH @ 20 Hour Rate deep cycle battery system.
Note: The battery pack must fit the battery compartment size listed in Specifications.

Wet Cell Battery Charger Specifications

- Use a 24 Volt DC output charger matching the DC battery pack voltage and the input AC line voltage supply being used.
- When selecting a battery charger always follow the recommendation of the battery supplier to match the proper charger DC output amperage to the amp/hour rating batteries being installed. This will prevent the battery pack from being over or under charged.

Wiring Diagrams

“Early” machines were built to accept the S.P.E. battery charger. These may have been modified to accept the Delta-Q IC650 battery charger. “Late” machines were built to accept the Delta-Q IC650 battery charger. The difference in the wiring diagrams is around the charger interlock circuit. If the machine you are working on, has a Delta-Q battery charger, use the “late” diagram. If it has the S.P.E charger, use the “early” diagram. If there is no charger, determine the correct diagram on the basis of the serial number.

Wiring (Ladder) Diagram: 56114061 Rev C (Early, before machine SN 3000167142)

Sheet 1 of 2

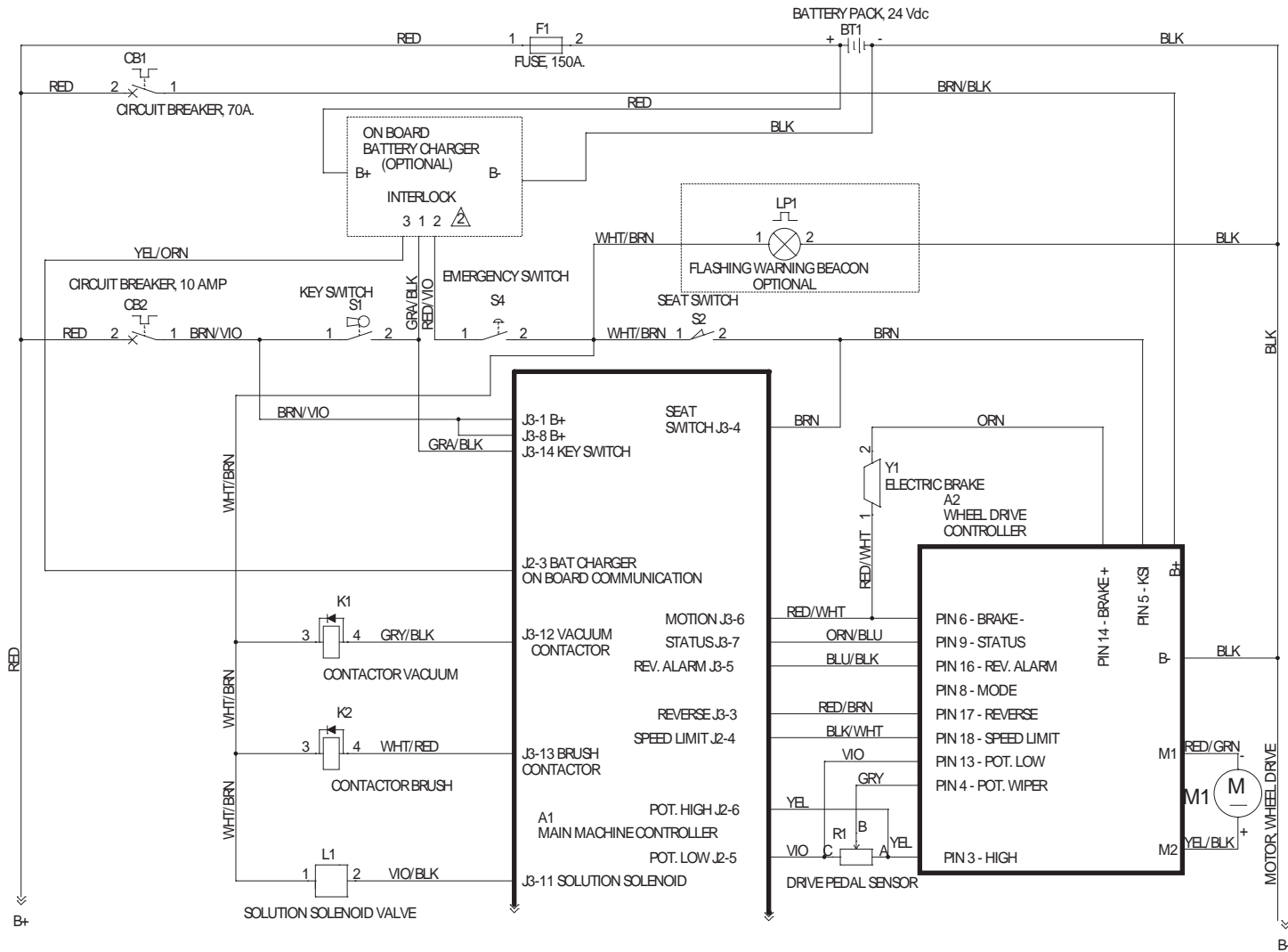

1. REFERENCE WIRING DIAGRAM 56114062

△ WHEN NO CHARGER IS PRESENT
INSTALL JUMPER BETWEEN
PIN 1 AND PIN 2

Sheet 2 of 2

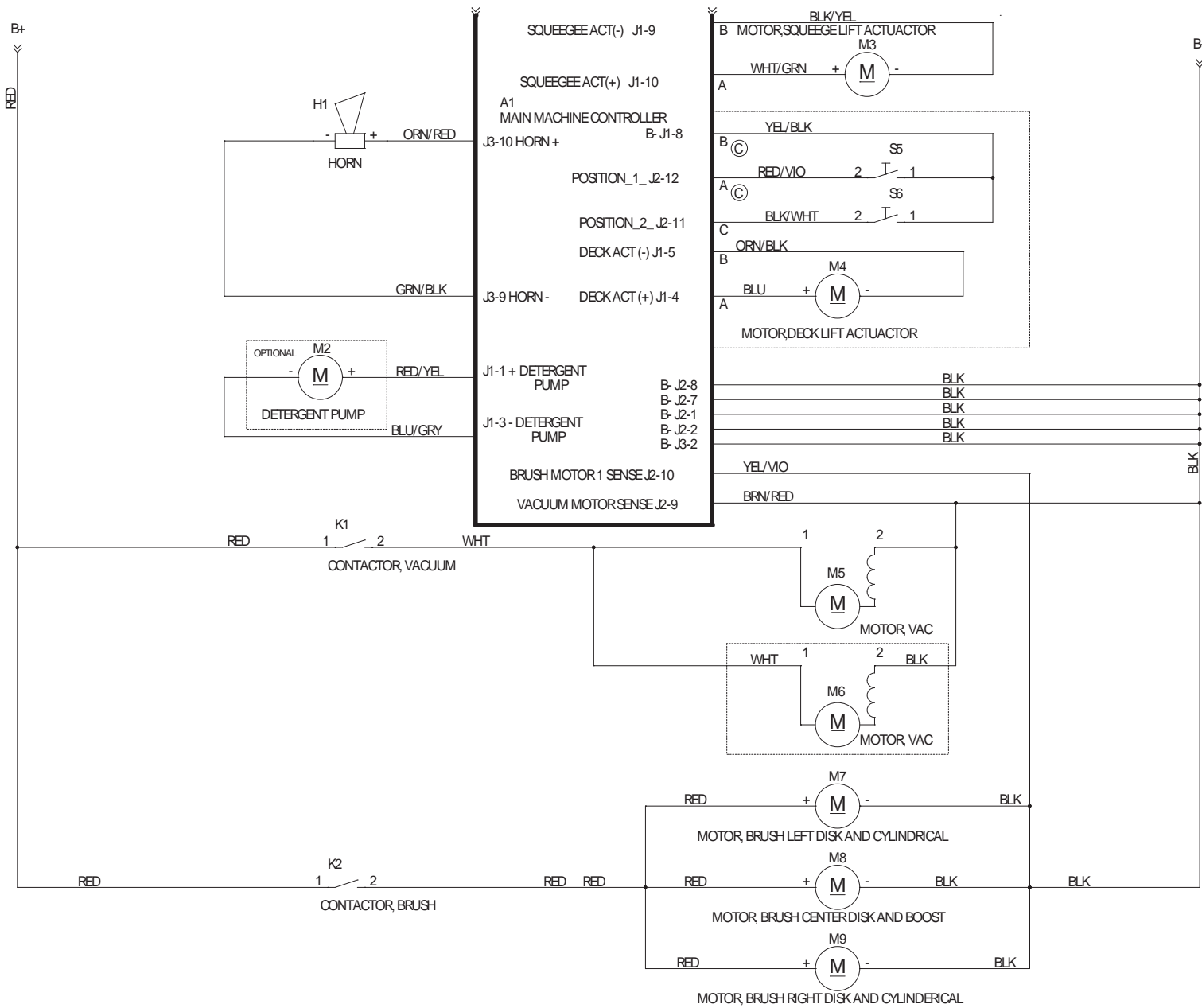

Wiring (Ladder) Diagram 56114404 Rev A (Late, beginning with machine SN 3000167142)

Sheet 1 of 2

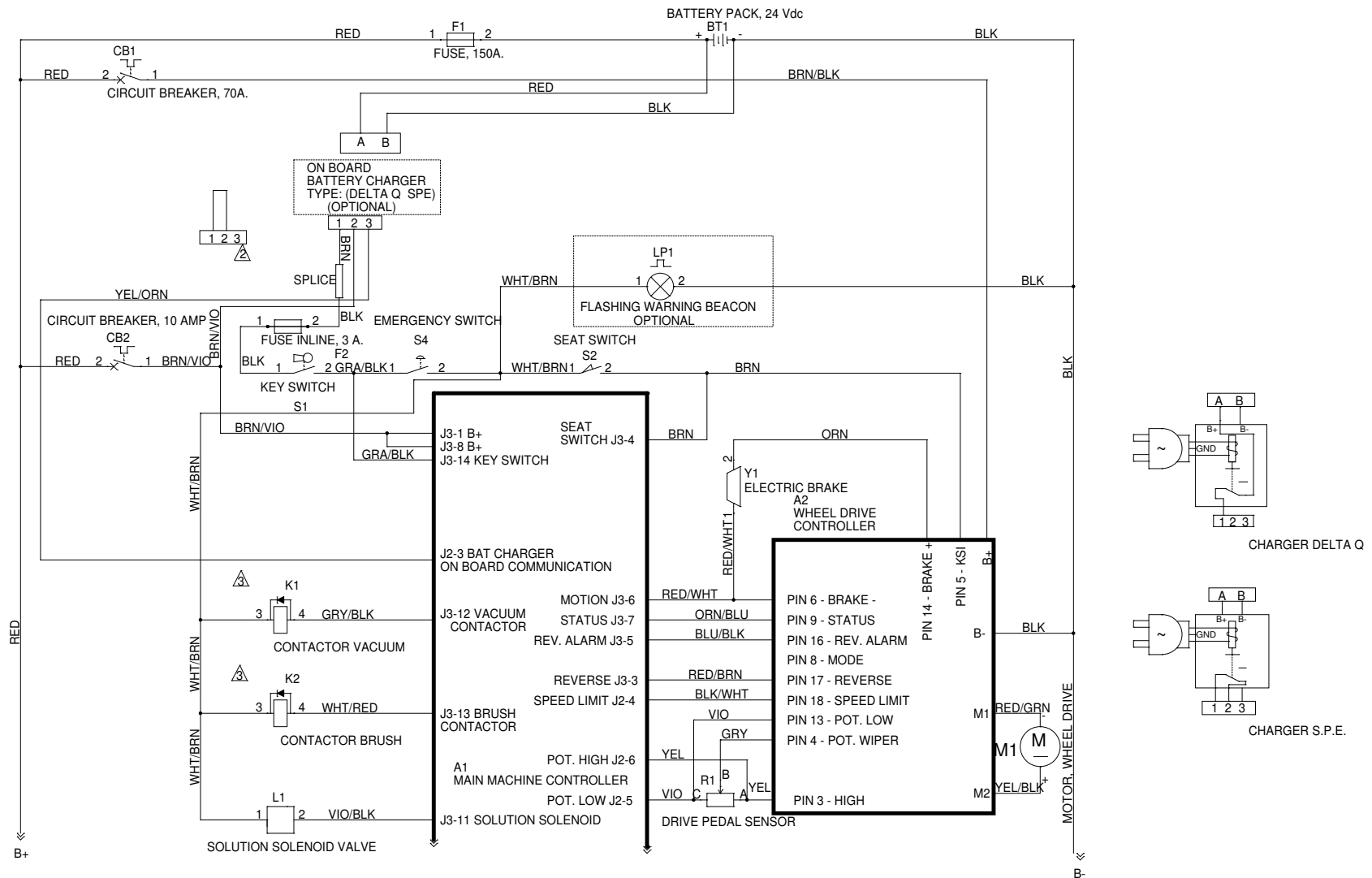

1. REFERENCE WIRING DIAGRAM 56114405

⚠ WHEN NO CHARGER IS PRESENT
INSTALL JUMPER BETWEEN
PIN 1 AND PIN 2

⚠ ADD RECTIFIER ASSEMBLY(56389265) TO CONTACTORS
K1 AND K2 AS SHOWN ON DIAGRAM

Sheet 2 of 2

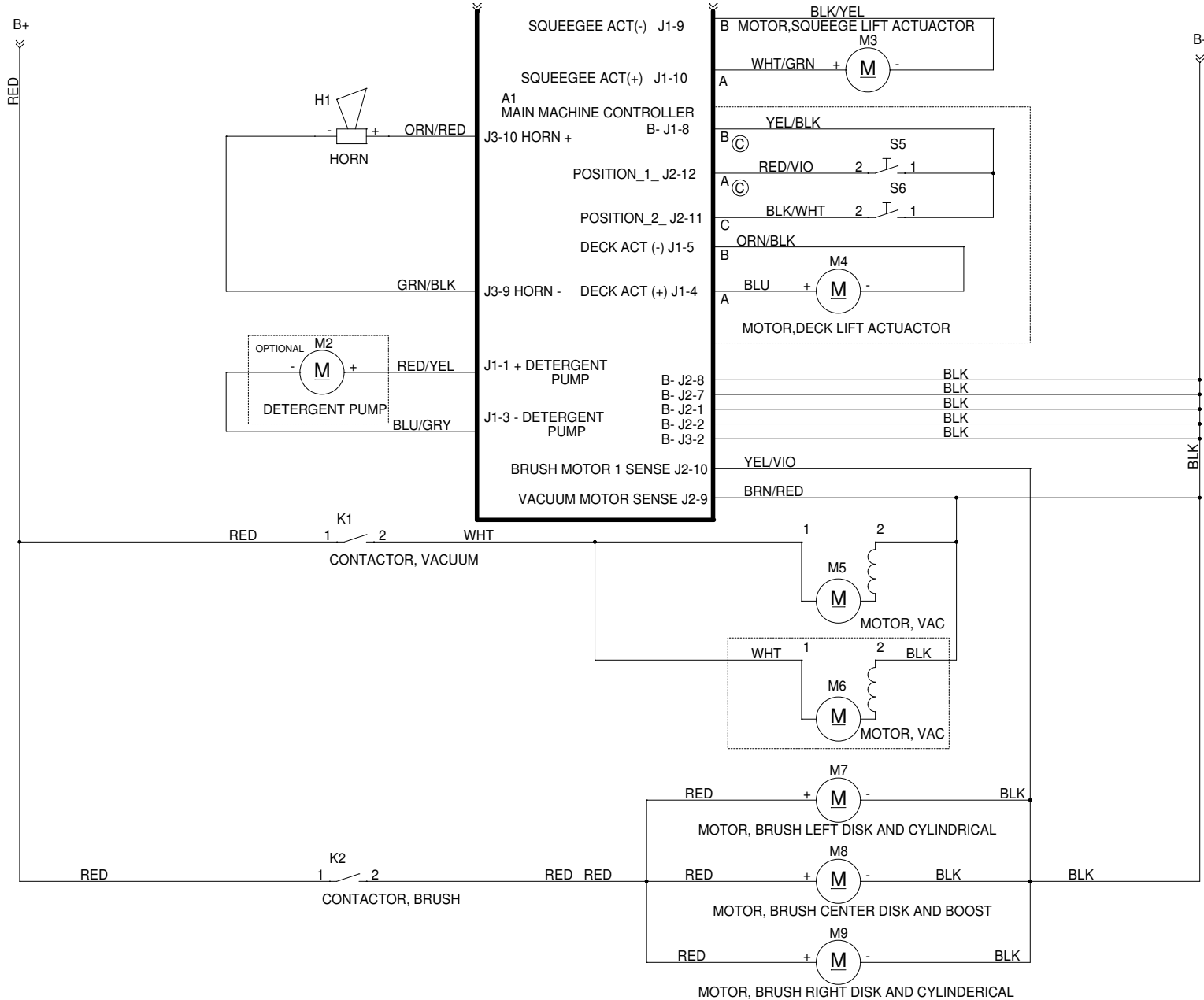

Wiring Harness Diagram: 56114062 Rev B (Early, before machine SN 3000167142)

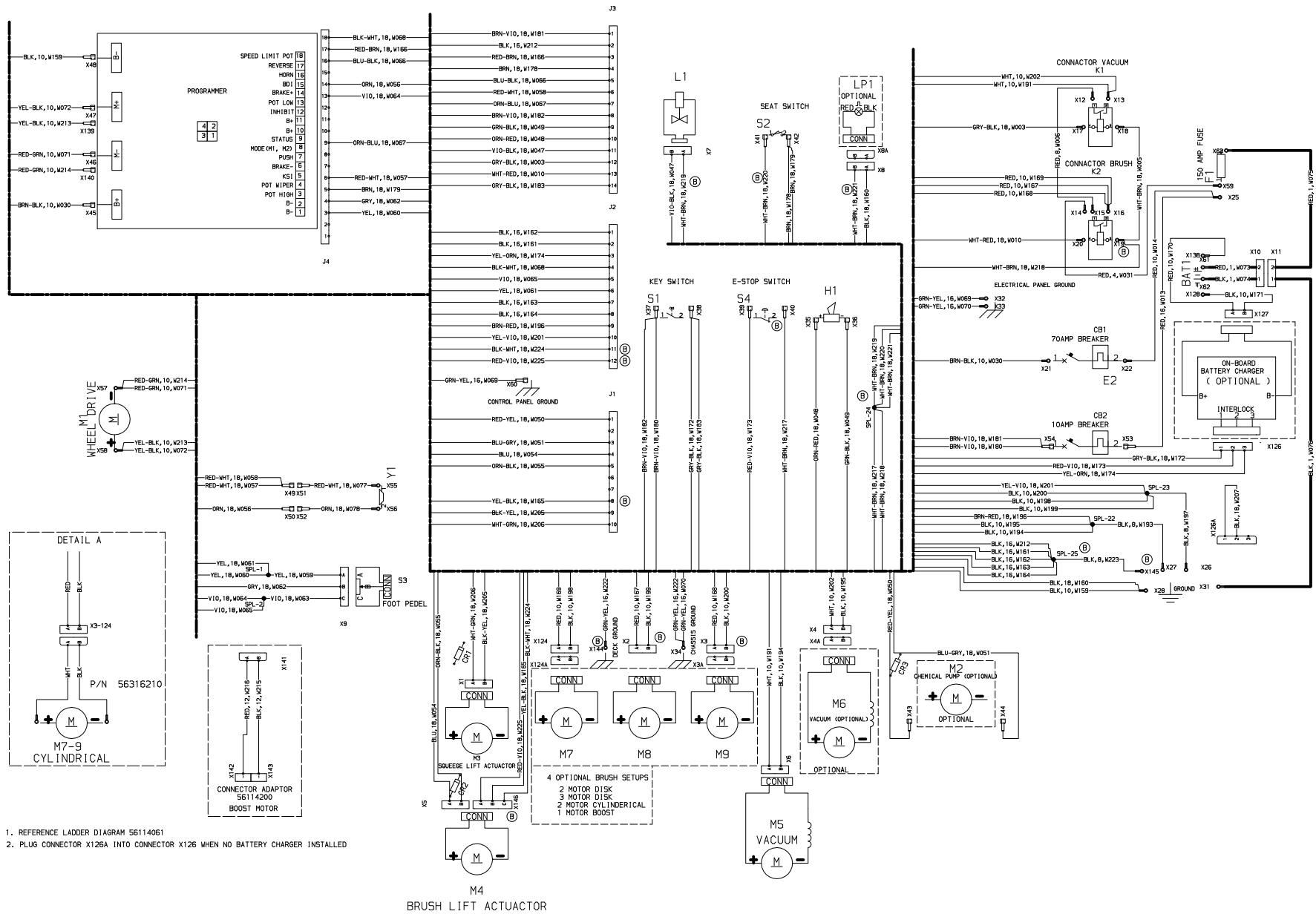

Wiring Harness Diagram: 56114405 Rev A (Late, beginning with machine SN 3000167142)

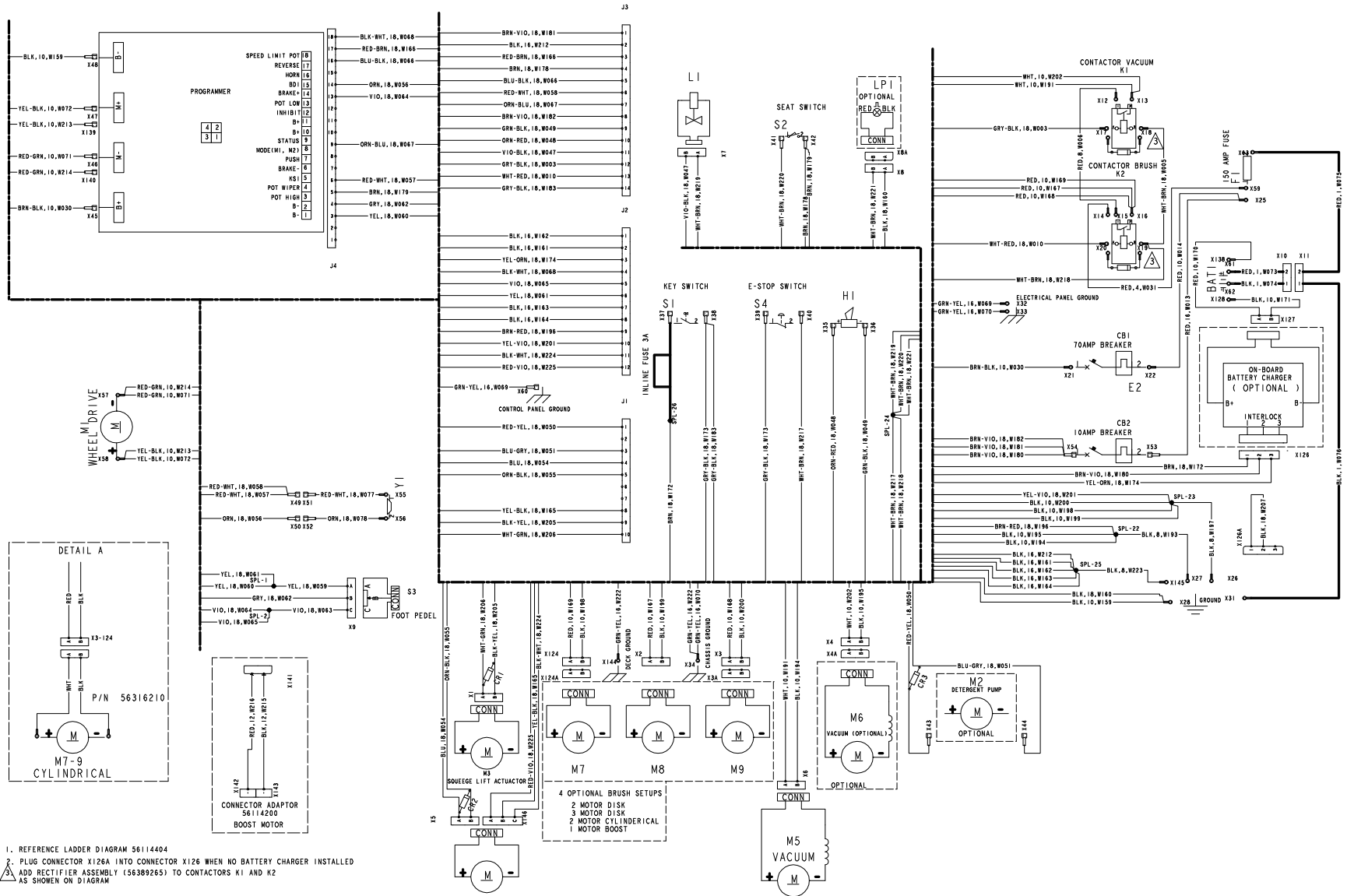

1. REFERENCE LADDER DIAGRAM 56114404
2. PLUG CONNECTOR X126A INTO CONNECTOR X126 WHEN NO BATTERY CHARGER INSTALLED
3. ADD RECTIFIER ASSEMBLY (56389265) TO CONTACTORS K1 AND K2 AS SHOWN ON DIAGRAM

-NOTES-

M4
BRUSH LIFT ACTUATOR

Connector Pinouts

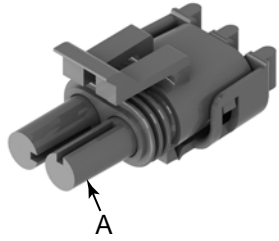
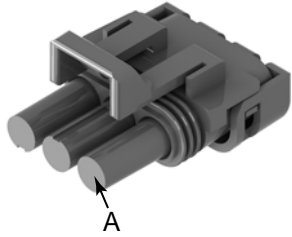
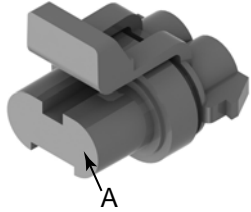
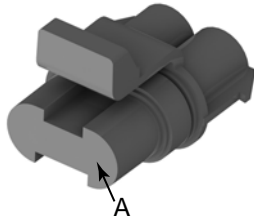
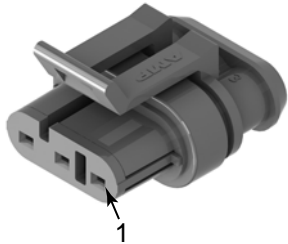
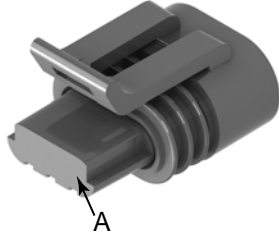
2 and 3 pin connectors				
ID	Name	Pin 1	Type	Style
M3	Squeegee Lift Motor	A = WHT/GRN, W206 B = BLK/YEL, W205	WP2	
L1	Solution Solenoid	A = WHT/BRN, W219 B = VIO/BLK, W047		
LP!	Beacon	A = BLK, W160 B = WHT/BRN, W221		
M4	Brush Lift Motor	A = BLU, W054 B = ORN/BLK, W055		
M4	Brush Lift Sensor	A = RED/VIO, W225 B = YEL/BLK, W165 C = BLK/WHT, W224	WP3	
M5	Vac Motor 1	A = WHT, W202 B = BLK, W191	MP2	
M6	Vac Motor 2	A = WHT, W202 B = BLK, W195		
M7	Brush Motor 1	A = RED, W169 B = BLK, W198	DUC2	
M8	Brush Motor 2	A = RED, W167 B = BLK, W199		
M9	Brush Motor 3	A = RED, W168 B = BLK, W200		
x126	Onboard Charger Interlock	1 = GRY/BLK, W172 2 = RED/VIO, W173 3 = YEL/ORN, W174	SUP3	
S3	Foot pedal	A = YEL, W059 B = GRY, W062 C = VIO, W063	MP3	

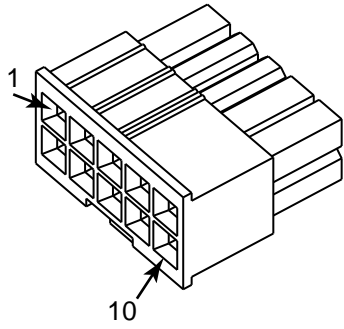
Main Machine Controller J1 Connector			
Pin #	Name	Wire Color, ID	
J1-1	Detergent Pump+	Red/Yel, W050	
J1-2	Not Used		
J1-3	Detergent Pump-	Blu/Gry, W051	
J1-4	Deck Lift+	Blu, W054	
J1-5	Deck Lift-	Orn/Blk, W055	
J1-6	Not Used		
J1-7	Not Used		
J1-8	B-	Yel/Blk, W165	
J1-9	Squeegee Lift+	Blk/Yel, W205	
J1-10	Squeegee Lift-	Wht/Grn, W206	

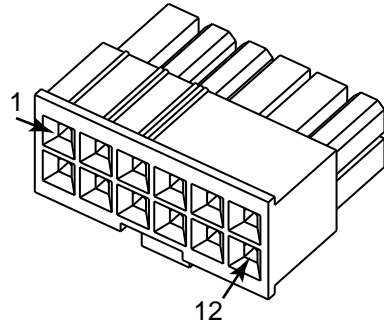
Main Machine Controller J2 Connector			
Pin #	Name	Wire Color, ID	
J2-1	B-	Blk, W162	
J2-2	B-	Blk, W161	
J2-3	Charger Comm	Yel/Orn, W174	
J2-4	Speed Pot Out	Blk/Wht, W068	
J2-5	Speed Pot Low	Vio, W065	
J2-6	Speed Pot High	Yel, W061	
J2-7	B-	Blk, W163	
J2-8	B-	Blk, W164	
J2-9	Vacuum Amps	Brn/Red, W196	
J2-10	Brush Amps	Yel/Vio, W201	
J2-11	Position 2 Switch	Blk/Wht, W224	
J2-12	Position 1 Switch	Red/Vio, W225	

Main Machine Controller J3 Connector			
Pin #	Name	Wire Color, ID	

J3-1	Power	BRN/VIO, W181
J3-2	Ground	BLK, W212
J3-3	Reverse_out	RED/BRN, W166
J3-4	Seat Switch	BRN, W178
J3-5	Reverse Signal	BLU/BLK, W066
J3-6	Fwd/Rev Signal	RED/WHT, W058
J3-7	Drive Status	ORN/BLU, W068
J3-8	Power	BRN/VIO, W182
J3-9	Horn-	GRN/BLK, W049
J3-10	Horn+	ORN/RED, W048
J3-11	Solution Solenoid1	VIO/BLK, W047
J3-12	Vac Contactor	GRY/BLK, W003
J3-13	Brush Contactor	WHT/RED, W010
J3-14	Key Switch	GRY/BLK, W183

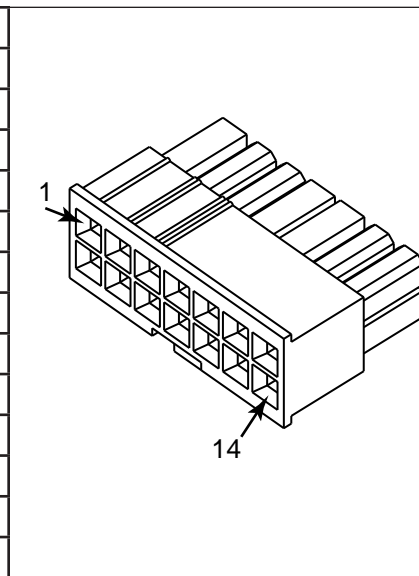

Options and Accessories

The Focus machine may be equipped with optional accessories, such as different scrub decks and squeegee sizes. It may also be equipped with the additional accessories described below.

- The most common additional accessory is the on-board battery charger. This is located below the operator's seat on the left side of the machine.
- The optional detergent injection system is located just below the operator's seat. The removable detergent cartridge (bottle) can be filled with concentrated detergent, and a small electric pump will inject this detergent into the solution line at a controlled ratio. Refer to the Solution System chapter beginning on page 67 for more information.
- The warning beacon may be added for increased visibility of the machine when it is operated in high traffic environments. The light operates whenever the machine is in a ready state to operate (key on and E-stop off).
- A second vacuum motor may be added for greater suction flow through larger squeegees. (The squeegee is typically sized according to the size of the scrub deck.)
- The Wand option is an add-on accessory that provides for spot cleanup in areas where the machine may not be able to reach. The wand connects to the vacuum hose leading to the squeegee.
- The Battery Fill Indicator provides a quick visual indication of when one of the battery cells is low and needs water added. It is installed in place of one of the battery fill caps. The wire lead goes to the battery negative terminal. When the level is Okay, the green LED is lit.

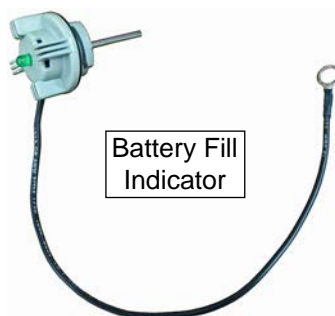

Recovery System

Functional Description

The recovery system extracts wastewater from the floor and deposits it into the on-board recovery tank. The floor squeegee is wider than the swath of the scrub deck to ensure collection of all wastewater from the perimeter of the scrubbing area. The squeegee also pivots to the side to permit operation near walls and to keep the squeegee within the scrubbing path while turning the machine.

Vacuum Motor and Recovery Tank

The vacuum motor generates airflow through the recovery tank and suction hose to the squeegee. The high velocity air at the squeegee pulls the wastewater off the floor and up through the suction hose. As the mixture of air and water enters the recovery tank, the airflow slows down due to the larger space, and the water drops out of the airflow and into the tank.

The airflow passes through an inlet screen to prevent debris from entering the impeller of the vacuum motor. The exhaust air is expelled inside the machine so it can be dispersed without blowing directly on the operator or the work environment.

To prevent wastewater from entering the vacuum motor, a float ball blocks the vacuum inlet when the recovery tank is full.

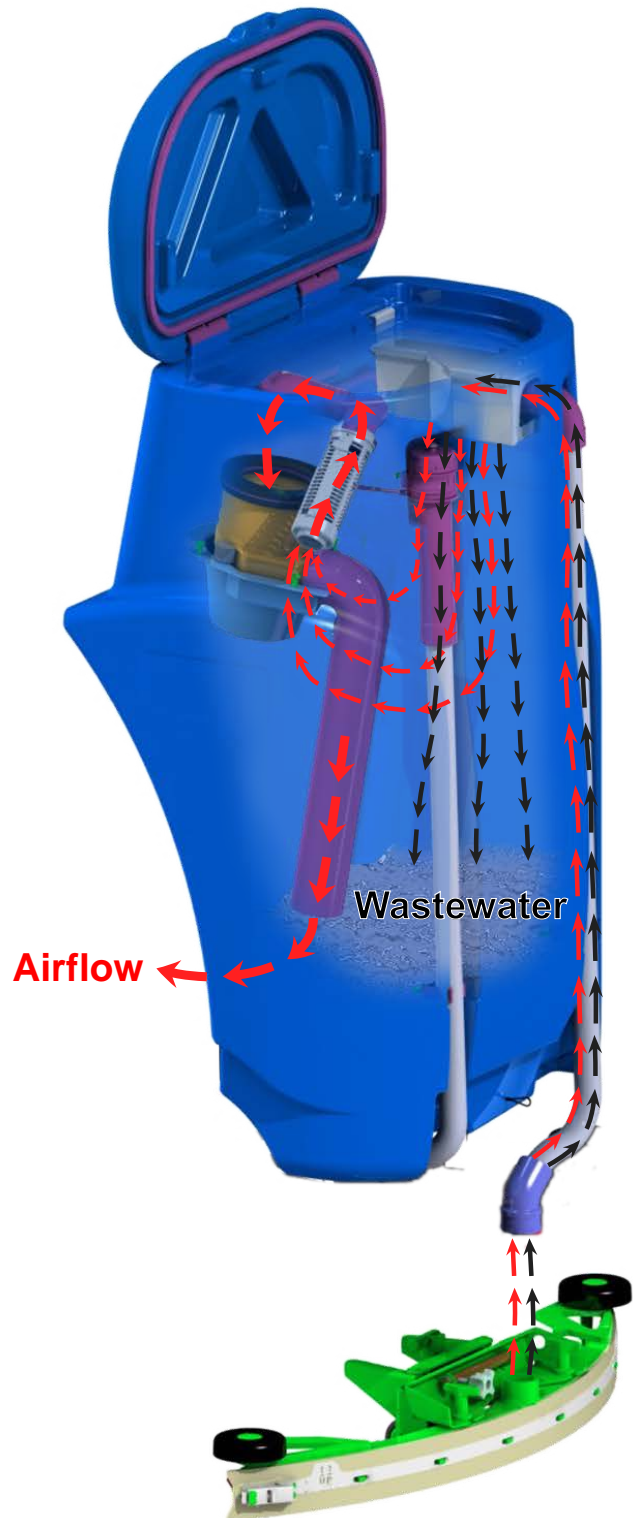

Vacuum Motor Control Circuit Overview

Power to the vacuum motor is controlled by a motor contactor, which is a motor-rated relay. When the contacts close, the circuit between the vacuum motor and the positive battery power is completed. The positive terminal of the contactor coil is energized whenever the key switch is on and the E-Stop is not engaged. The negative terminal of the contactor coil is controlled by the Main Machine Controller.

The contactor coil is controlled by the switching of the negative terminal via the J3-12 terminal of the Focus II control board (A1). The output of the J3-12 terminal is PWM controlled to reduce the effective voltage on the contactor’s coil. This PWM signal does not impact the actual vacuum motor voltage, only the coil’s voltage. The PWM signal begins high to pull the contacts together, and then reduces power to just enough to hold the contacts closed.

The Main Machine Controller monitors the performance of the vacuum motor by observing the voltage drop across the negative power wire leading to the motor. The more current flowing through the wire, the larger the voltage drop. The controller uses this voltage reading to calculate the amperage running through the motor.

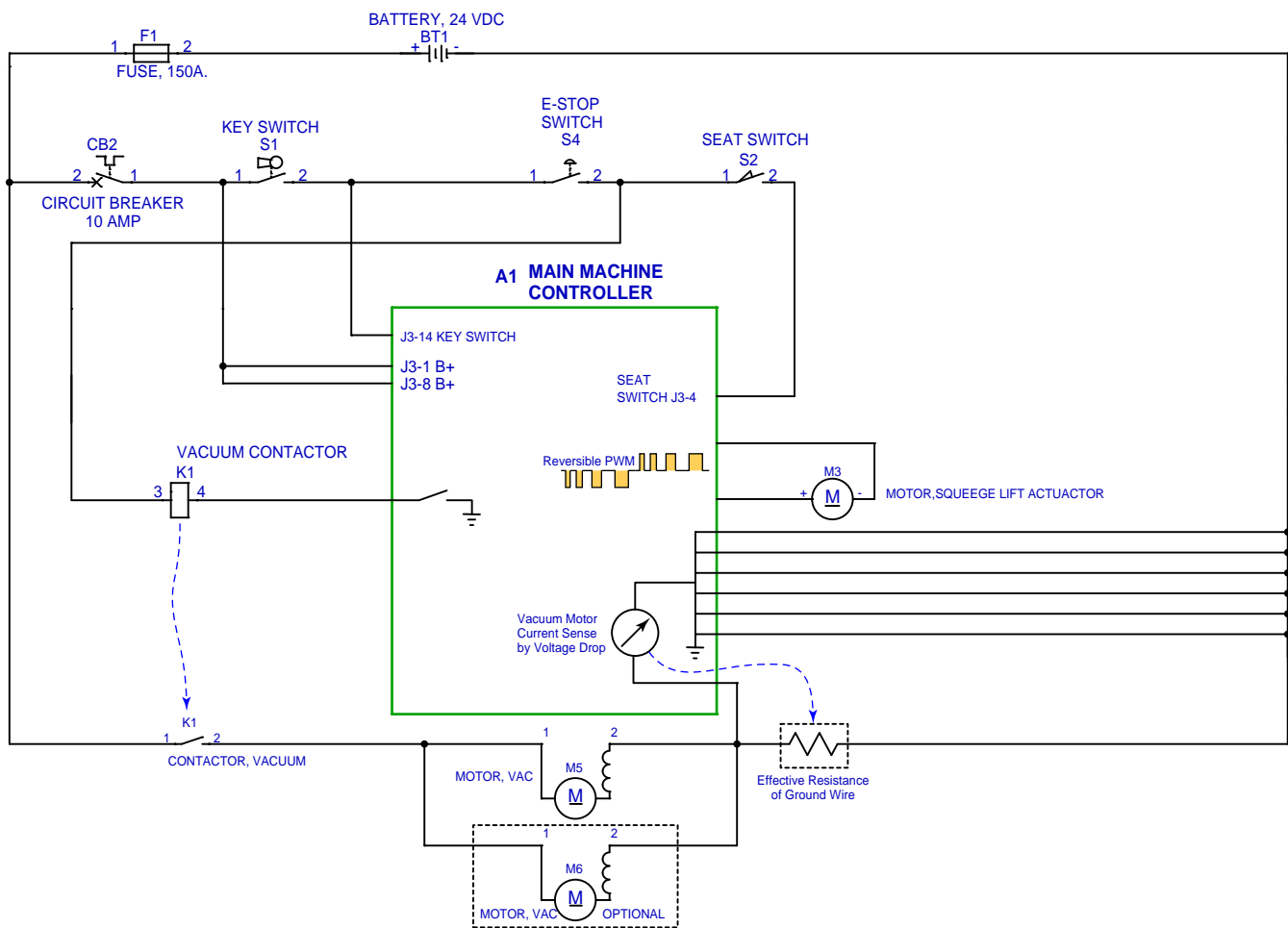

Troubleshooting

Whenever there is a vacuum problem, it's best to check over the entire system. Use the checklist below as a guide to thoroughly check the vacuum system.

- Inspect and clean the vacuum motor float ball. If the ball is dirty, it may get stuck in the closed position, or close enough to it to be drawn into the closed position from the moving airflow.
- Inspect the vacuum motor inlet screen and clean any built-up debris from the screen.
- Clean built-up dirt from the inside of the squeegee tool.
- Replace the squeegee blades if they are nicked or torn.
- Inspect the hose between the squeegee tool and the recovery tank and rinse any built-up dirt from the hose. Replace the hose if it is kinked or damaged.
- Inspect and make sure the gasket on the recovery tank cover is sealing and not damaged.
- Make sure that the recovery tank drain hose cap seals airtight.

Problem	Cause	Correction
No suction	Vacuum motor not running	<ul style="list-style-type: none"> • Check the vacuum motor power connector • Check the vacuum motor contactor for proper operation
Poor suction	Unknown: Leak versus Clog	<p>To determine whether the problem is a leak versus a clog, remove the suction hose from the squeegee and completely block the hose with your hand and observe the suction. Then tilt your hand to allow free airflow, and observe the speed of the airflow past your hand.</p> <p>Alternatively, you may complete the Vacuum Suction Test described on page 51.</p> <ul style="list-style-type: none"> • Strong suction when blocked and weak airflow when unblocked indicates a clog. • Weak suction when blocked, but strong airflow when unblocked indicates a leak. • Weak suction and weak airflow indicate either a massive leak, or a failing vacuum motor.
	Clogged vacuum	<ul style="list-style-type: none"> • Inspect and clean the vacuum motor inlet filter • Inspect the suction hose between the squeegee tool and the recovery tank • Inspect and clean the squeegee tool
	Vacuum leaks	<ul style="list-style-type: none"> • Inspect the gasket on the recovery tank cover • Inspect the suction hose between the squeegee tool and recovery tank for loose connection, holes, or damage • Inspect the squeegee blades for nicks, cuts, and damage • Inspect the recovery tank drain hose and cap for leaks • Inspect the vacuum motor mount for leaks

Vacuum Suction Test

Use this procedure to verify that the vacuum system is performing within factory specifications. This procedure can also be used to isolate the cause of a vacuum problem between a clog or leak. It is a two-part procedure that verifies both static pressure and flow rate. This procedure requires a vacuum gauge (PN 56205281), a piece of 1½" PVC (or similar) tube, a 1" hole saw, and some duct tape (or similar, for a seal).

1. Remove the suction hose (3) from the squeegee and then turn on the vacuum.
2. Place the vacuum gauge (7) on the hose so the taper (7A) seals against the end of the hose (3A).
3. Record the vacuum pressure reading from the gauge. This is the static pressure.
4. Turn the vacuum off while constructing and fitting the PVC restrictor tube (8).
5. Cut a piece of 1½" PVC approximately 6" long, and clean off the burs. The outer diameter of the tube should be close to, but not larger than 2".
6. Drill a 1" hole (8A) approximately in the middle of the PVC tube, and clean off the burs.
7. As necessary, wrap duct tape (8B) around the tube so it fits snugly in the end of the end of the suction hose (3A) with no leaks.
8. Turn the vacuum on and place the vacuum gauge on the restrictor tube.
9. Record the vacuum pressure reading from the gauge. This is the restricted flow pressure.

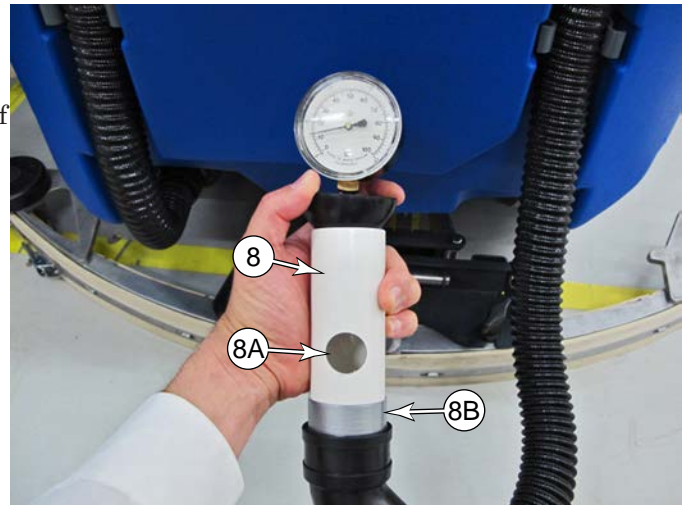

Results Summary

The first part of this procedure determined the static pressure of the vacuum system, and the second part determined the flow rate (by calculation). The flow rate through a restriction (8A) is determined by the pressure differential across the restriction. These two parameters may be used to determine if the vacuum system is functioning properly, and may also be used to isolate a possible cause for a problem.

- If the static pressure is at least 55 psi, then the vacuum motor(s) are functioning properly and there are no significant leaks in the system.
- If the restricted flow pressure is at least 10 psi for a single vacuum, or 20 psi for a dual vacuum, then there are no significant clogs in the system.
- If both parameters are below specifications, then one or both vacuum motors may be failing, or there may be a significant leak in the system.

Removal and Installation

Recovery Tank

Removing the recovery tank is generally a prerequisite procedure for completing other maintenance procedures and gain access to other components.

1. Turn off the main key switch.
2. Remove the drain hose cap (2), and drain the recovery tank. You may also wish to rinse and flush the tank before removing it.
3. Lift the operator's seat and disconnect the power connector (5) for the vacuum motor. If there are two vacuum motors, make sure to disconnect both of them.
4. Remove the suction hose (3) from the squeegee (4).
5. To protect the squeegee from inadvertent damage, you may wish to remove it from the machine.
6. Lift the recovery tank off the main machine.



Vacuum Motor

1. Drain and remove the [Recovery Tank](#) described on page 52.
2. Remove the four screws (**6A**) and washers (**6B**) that secure the vacuum motor housing (**6C**) to the recovery tank, and remove the housing. Be careful not to let the motor fall, as the housing is what holds it in place.
3. Remove the vacuum motor (**6**) and discharge hose (**6G**). Take care not to lose the three vibration mounts (**6D**).
4. If necessary, remove the cable tie that secures the discharge hose to the motor outlet.
5. Inspect the main vacuum gasket (**6E**) for damage and compressibility, and replace if necessary. Leaks in this gasket will reduce recovery system suction.
6. Inspect the motor ventilation gasket (**6F**) for damage and compressibility. This gasket holds the vacuum motor assembly in position against the recovery tank.
7. Make service repairs to the vacuum motor as needed, and re-install by reversing the procedure steps.

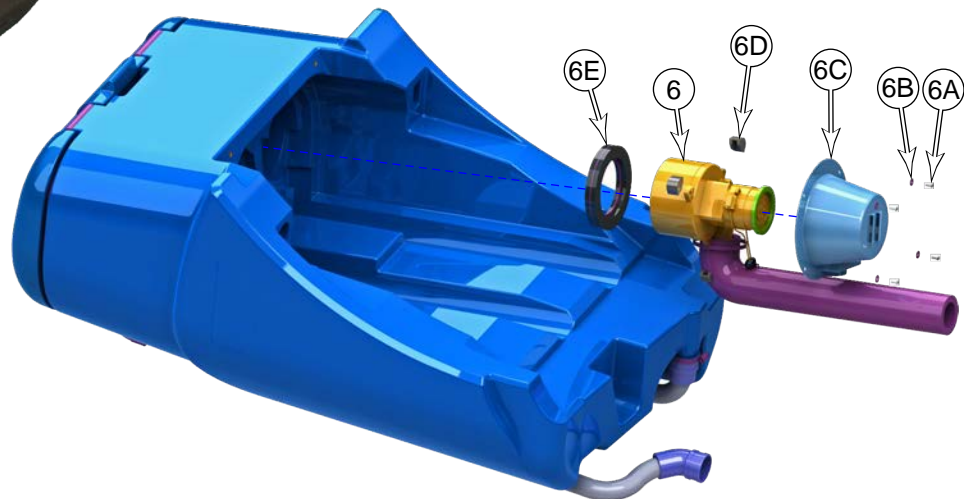
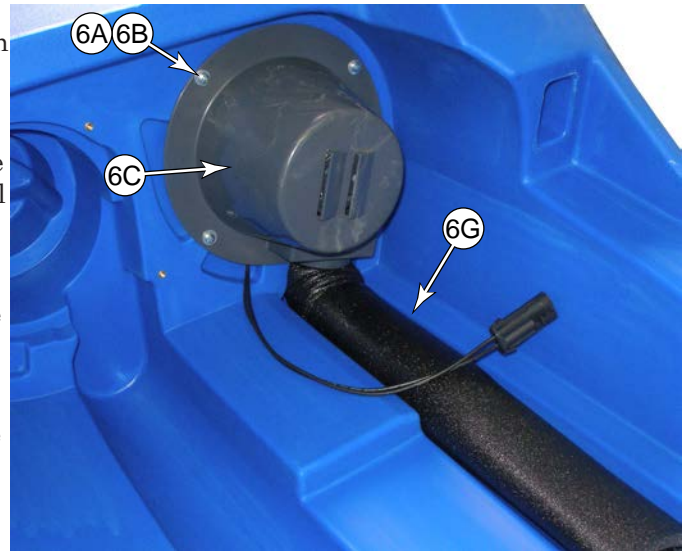

Specifications

Parameter	Range
Vacuum Lift, Single Motor	<ul style="list-style-type: none"> Sealed water lift = 61 in-H₂O (15 kPa) 1-inch open hole aperture = 8 in-H₂O (2 kPa)
Vacuum Lift, Dual Motor	<ul style="list-style-type: none"> Sealed water lift = 59 in-H₂O (15 kPa) 1-inch open hole aperture = 21 in-H₂O (5 kPa)
Contactors Coil Resistance	<ul style="list-style-type: none"> 58.3 Ω
Motor Amperage	<ul style="list-style-type: none"> Single Motor, with squeegee off floor = 19.8 A Dual Motor, with lid open = 40 A Dual Motor, with 1" hole = 38 A Dual Motor, blocked inlet = 30 A

Special Tools

Vacuum Pressure Gauge
part number 56205281



1-inch open hole adapter
Fabricated from PVC



Scrub System: Disc, Cylindrical, & Boost

Functional Description

The Focus machine can be configured for a variety of different scrub deck types and sizes. Depending on the size, the disc-type deck may have two drive motors or three drive motors. Each type is described in greater detail below.

Deck Lift

The deck lift mechanism and deck lift actuator control the raising and lowering of all deck types. All deck types and sizes mount universally to the deck lift linkage. The raised position of the lift actuator is the same for all deck types, and is controlled by a limit switch inside the actuator. The operating position for the disc and cylindrical decks is controlled via feedback of the amperage of the brush motors. Positioning for the boost deck does not use amperage feedback. Instead, an extra set of position switches are located inside the lift actuator to tell the controller when the deck is in one of two operating positions.

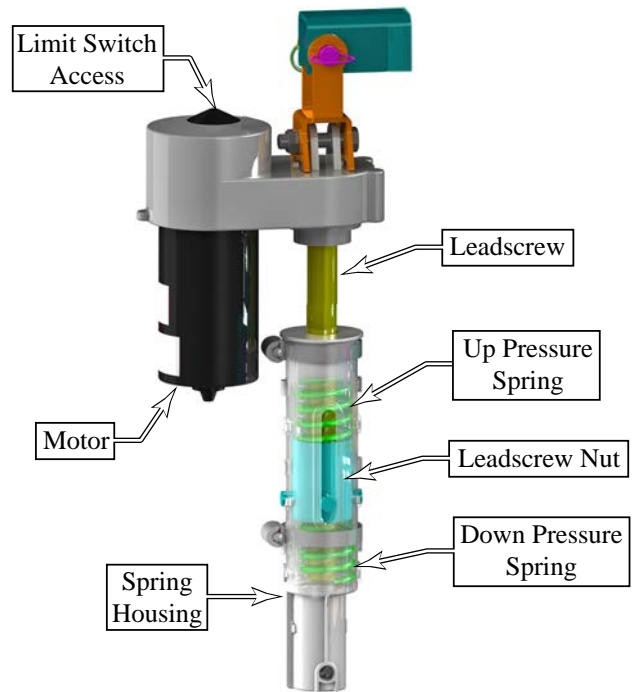

Drive Motors

Unlike most other motors in the Focus system, the Brush motors are not PWM speed controlled, but are either full-on or full-off. The primary on/off function is controlled with the brush motor contactor (**K1**) located in the main electrical panel under the operator's seat. The output of this contactor is all-on or all-off, but the power to the coil is PWM controlled to increase the life of the coil. At the time of the initial contact closure, the controller provides a full PWM signal to the coil to pull the contacts closed, but then reduces the PWM duty cycle while holding the contacts closed because less power is needed to keep them closed versus pulling them closed.

Disc Deck

The disc deck is available in 3 sizes. The 28" and 34" decks use two drive motors and two brush discs, and the 40" deck uses three motors and three brush discs. The machine uses the same wiring harness for all deck types, so it is important to program the controller to know what type of deck is installed.

The two or three drive motors connect to their respective brush discs through a right angle gear boxes. The rotation direction of the individual brushes is dictated by the rotation of the gear box, instead of changing the electrical polarity of the motor. This allows the motors to be connected in any fashion to the wiring harness.

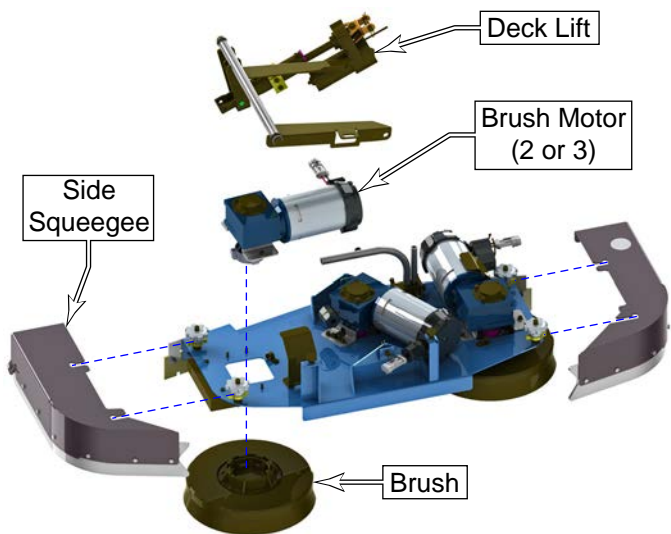

Cylindrical Deck (Nilfisk-Alto models only)

The cylindrical deck uses two counter-rotating horizontal brushes. Each brush is driven by its own motor via a drive pulley. The counter-rotation is achieved because both motors rotate the same direction, but are facing in opposite directions from one another.

The cylindrical deck uses the same current sensing methodology for detecting brush pressure as the disc deck, but with slightly different values and for only 2 motors.

The counter rotating motion of the brushes permits large debris to be propelled into the hopper behind the deck.

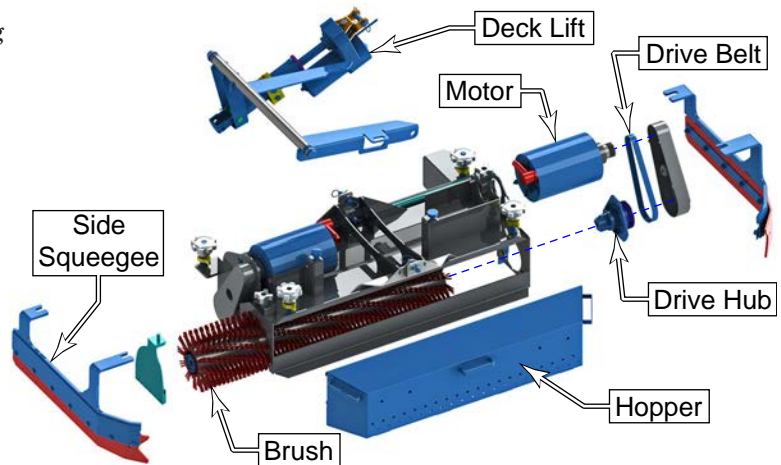

Boost Deck (Clarke models only)

The boost deck operates on an orbital motion instead of a rotational motion. The rectangular pad moves in a small circle but does not rotate. This orbital movement is created from an eccentric lobe, where the rotation of the motor's shaft is off-axis from the center of the pad. Rubber isolation mounts allow the pad to move in this small circular motion without rotating.

Because this small orbital motion results in a significant mechanical advantage for the motor's rotation, current sensing for determining the deck pressure results in only small variations in motor current for large variations in deck pressure. For this reason, current sensing is not used for deck pressure control.

The lift actuator contains two extra position switches to tell the controller what the physical position is of the deck height. From these heights, deck pressure is mathematically determined from the amount of spring compression within the actuator's leadscrew.

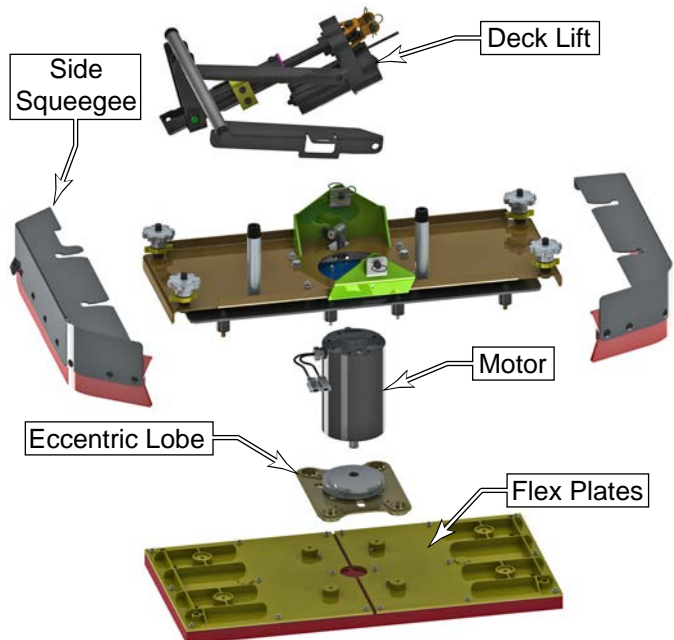

Circuit Overview

Scrub Deck Motors

Depending on the configuration of the machine, there will be 1, 2, or 3 brush motors. All motors are connected in parallel from the same wiring harness. Power to the brush motor(s) is controlled by a motor contactor, which is a motor-rated relay. When the contacts close, the circuit between the brush motor and the positive battery power is completed. The positive terminal of the contactor coil is energized whenever the key switch is on and the E-Stop is not engaged. The negative terminal of the contactor coil is controlled by the Main Machine Controller.

The contactor coil is controlled by the switching of the negative terminal via the J1-13 terminal of the Focus II control board (A1). The output of the J3-13 terminal is PWM controlled to reduce the effective voltage on the contactor's coil. This PWM signal does not impact the actual brush motor voltage, only the coil's voltage. The PWM signal begins high to pull the contacts together, and then reduces power to just enough to hold the contacts closed.

The Main Machine Controller monitors the performance of the brush motor(s) by observing the voltage drop across the negative power wire leading to the motor. The more current flowing through the wire, the larger the voltage drop. The controller uses this voltage reading to calculate the amperage running through the motor.

The controller uses this calculated amperage to determine the scrub pressure of the deck. The controller then raises and lowers the height of the scrub deck to keep the brush motor amperage within its desired range.

Deck Lift Actuator

The deck lift actuator is powered directly from the Main Machine Controller. The Main Machine Controller needs to reverse the polarity and power level to this motor in order to raise and lower the deck in very small amounts to maintain pressure. The signal from the controller is reversible Pulse-Width Modulated (PWM). (Refer to the [Drive Motor System Function](#) described on page 79 for more information on PWM control.)

The deck lift actuator contains two additional position switches (S5 & S6) not found in other actuators on the machine. These switches provide position feedback to the controller, so the controller knows the height of the deck independently from the amperage load on the brush motor(s). This permits the controller to set the initial deck height more accurately than just approximating the position based on how long the motor rotates. These switches are normally open, and they close when the respective position is reached.

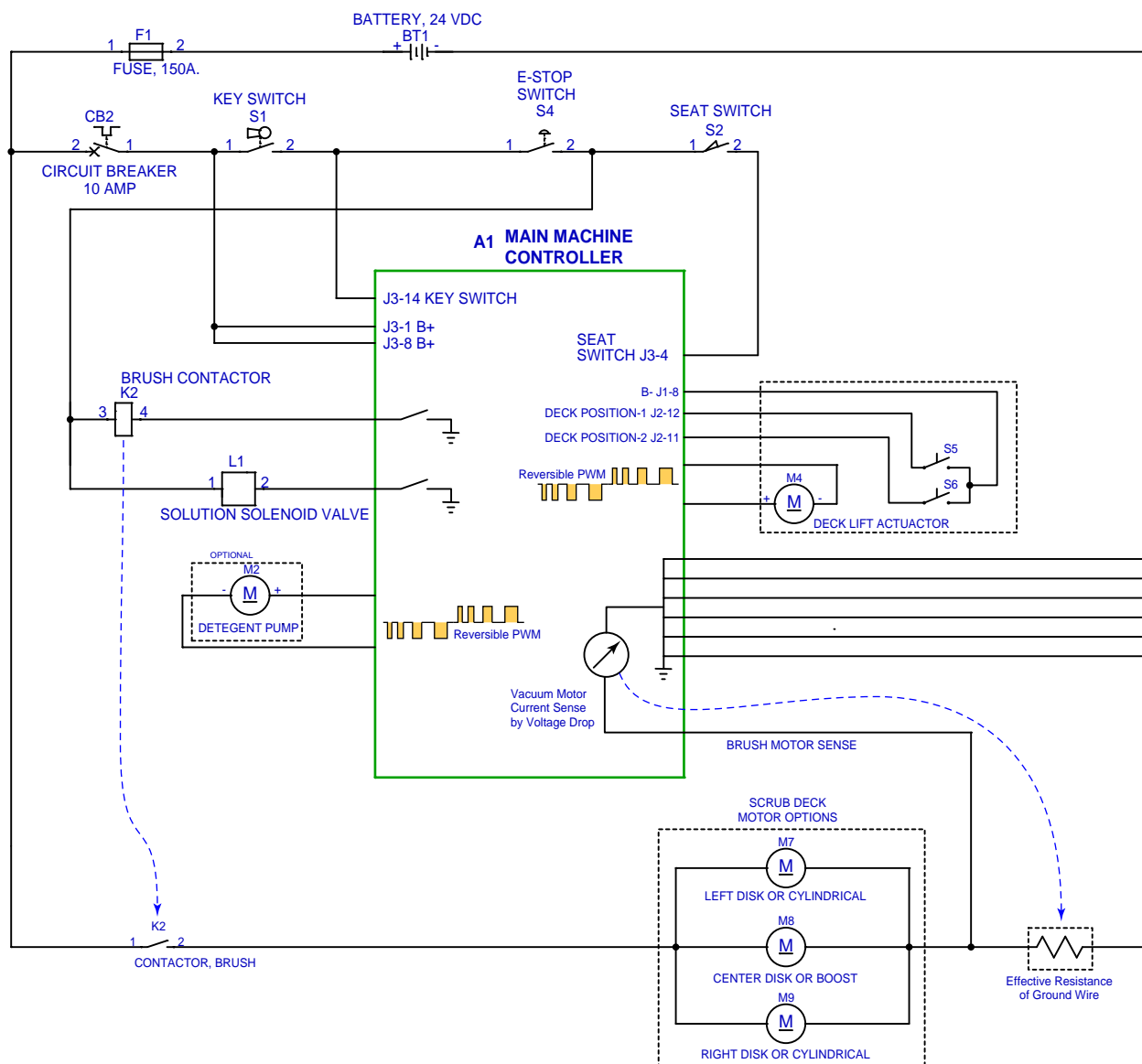

Maintenance and Adjustment

Lift Actuator Limit Adjustment

To protect the lift actuator from traveling too far, it contains internal limit switches for minimum and maximum travel. This adjustment requires the use of the Actuator Power Cord Adapter (99) (PN 56407502) shown to the right.

Important: If this procedure is being completed on a new actuator, it is important that you check the orientation of the nut and springs inside the spring housing. Refer to [Deck Lift Actuator](#) described on page 61.

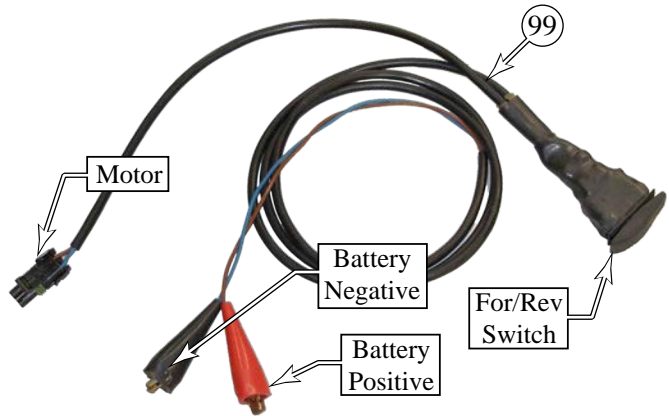

1. This procedure is best performed on a work bench. Remove the [Deck Lift Actuator](#) described on page 61.
2. Connect the Power Cord Adapter (99) to the positive and negative battery terminals of the Focus II machine.
3. Connect the other end of Power Cord Adapter (99) to the motor's power connector. (The position switch connector is not needed for this procedure.)
4. While holding the spring housing (2C) from turning, press the For/Rev switch on the Adapter (99) to move the spring housing (2C) until the actuator reaches its limit switch and the motor stops:
 - For Boost and Disk decks, move the actuator to its extended position.
 - For Cylindrical decks, move the actuator to its retracted position.
5. Rotate the spring housing (2C) until the distance between the spring housing and gear housing (2M) is as follows:
 - 3.94±0.06 inches (extended) for Disk and Boost decks
 - 0.75±0.09 inches (retracted) for Cylindrical decks.

Important: After the limit is adjusted and until the actuator is back in the machine, make sure not to rotate the spring housing relative to the motor housing.

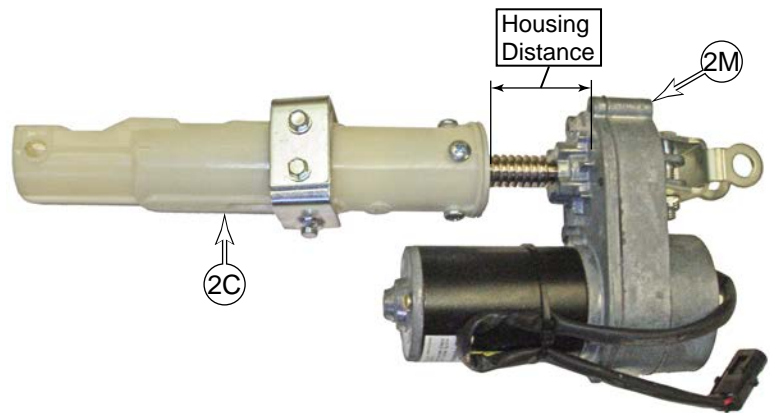

6. Before disconnecting the Adapter cord (99), move the spring housing back to the approximate position it was in when you removed it from the machine. Leave the adapter cord connected to the battery, but unplug it from the motor while reinstalling the actuator.
7. Reinstall the actuator on the machine.
8. If necessary, use the adapter cord to raise or lower the mechanism to make it easier to reinstall the scrub deck. Take care to not allow the spring housing to rotate.

Removal and Installation

Note: Three basic deck types are available for this machine. When a specific deck type is not critical to a procedure, it will be given a (1x) item designation. When a deck type is critical to a procedure, it will be given a designation as follows: 3x-Disc, 4x-Cylindrical, and 5x-Boost.

Scrub Deck

Removing the scrub deck may be helpful for accessing other components. It may also be necessary to switch from one style/size scrub deck to another. The same procedure is used for all scrub deck types. Some images may not match this scrub deck style.

1. Using [Service Test Mode](#) described on page 22, lower the scrub deck to a neutral position on the floor, and then turn off the key switch (A).
2. For easier access to the upper retaining pin (2A), and a better view, you may wish to remove the [Electrical Panel Cover](#) described on page 37.

Note: For machines equipped with the onboard detergent system, this access is behind the detergent panel instead.

3. Loosen the hose clamp and remove the solution line (6) from the solution solenoid (7) located on the right-hand side of the machine.
4. Disconnect the scrub brush motor power connector(s) (8), and free up the cables from any cable ties.

Note: During reassembly, make sure unused motor plugs are fitted with protective caps (9).

5. Depending on the deck type and the arrangement of the deck pins (1B), it may be necessary to remove the upper retaining pin (2A) from the Deck Lift Actuator (2) and move the actuator slightly to the side.

- The easiest way to access the upper pin (2A) is from below, but while looking through the opening behind the electrical panel (or detergent cartridge) (10).
- Take care not to rotate the actuator (2) while it is disconnected, as this will effect its adjustment.

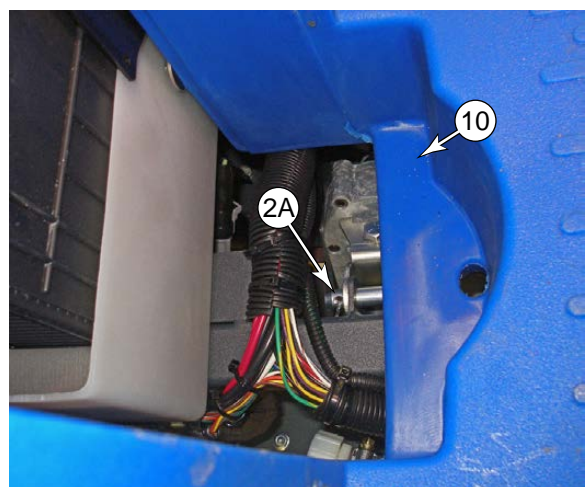
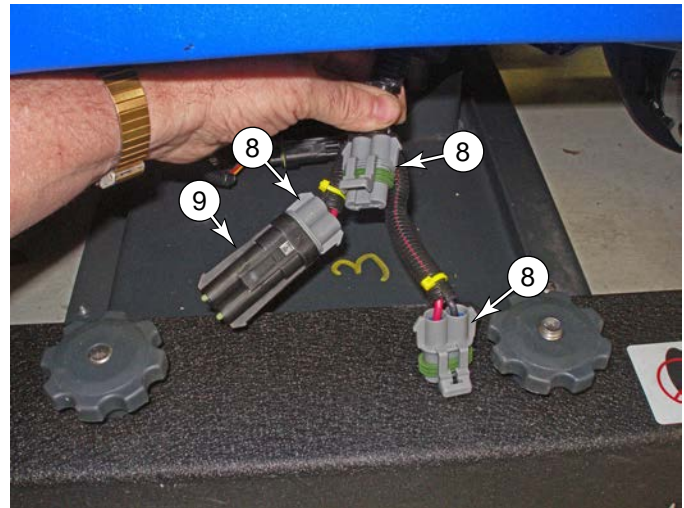
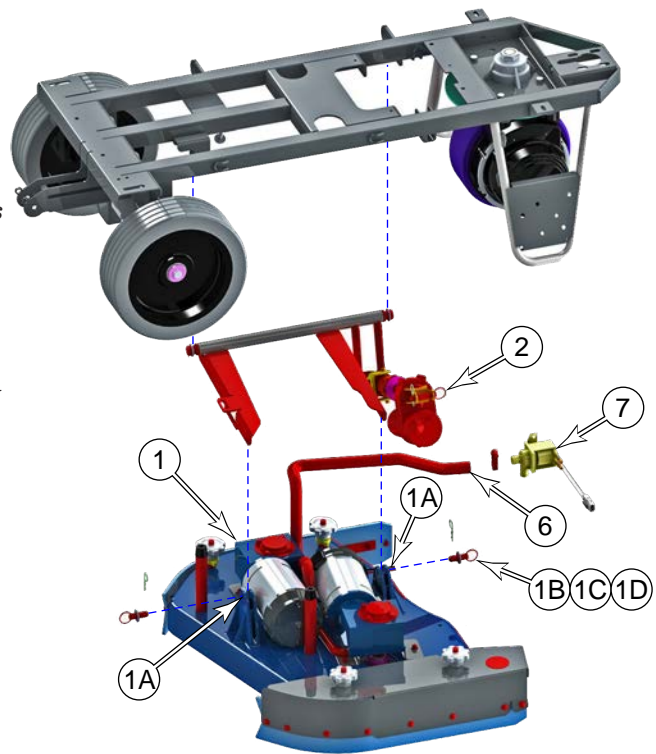

6. From the right side of the machine, remove the retaining key (1C) and link pin (1B) that secures the scrub deck to the lift arms. Take care not to lose the spacers (1D).
7. Slide the scrub deck out from the right side of the machine. Make sure no wires or hoses get hung up on the deck as you remove it.
8. Install the replacement deck, or reinstall the existing deck following the reverse order of the previous steps.
9. Make sure to secure the wiring harnesses out of the way with cable ties.

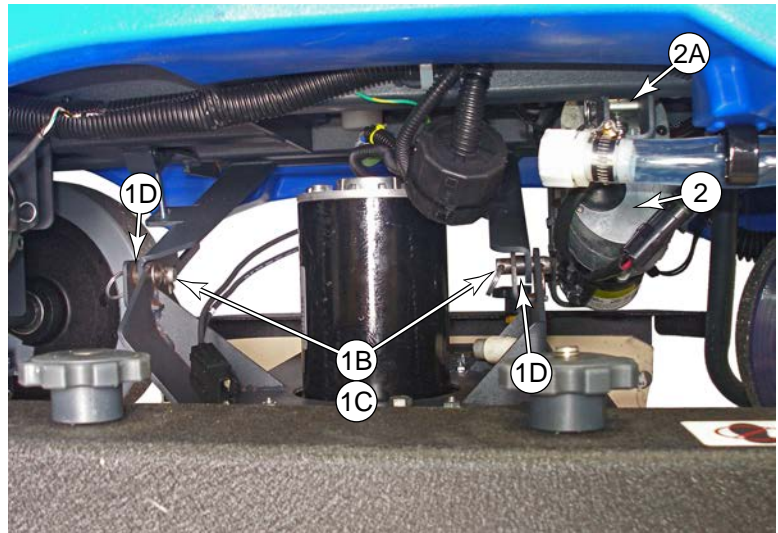

Deck Lift Actuator

1. For easier access to the actuator, you may wish to remove the [Scrub Deck](#) described on page 59.
2. For a better view of the upper retaining pin, you may wish to remove the [Electrical Panel Cover](#) described on page 37, or if so equipped, the detergent system panel.
3. Disconnect the electrical power and position switch connectors to the lift actuator.
4. Remove the upper pin (**2A**) from the lift actuator by reaching in from below the machine while looking through the opening behind the electrical panel (or detergent cartridge) (**10**).
 - If the actuator is going to be reinstalled without modification, take care not to rotate the spring housing relative to the motor/ leadscrew. If they remain unchanged, you can reinstall the actuator without performing the limit adjustment procedure.
5. Remove the lower pin (**2B**) and remove the actuator.
6. If the same actuator is being replaced back onto the machine, then perform the [Lift Actuator Limit Adjustment](#) described on page 58 before replacing the actuator.
7. If a new actuator is being installed, then confirm the orientation of the springs and nut described on the next page.

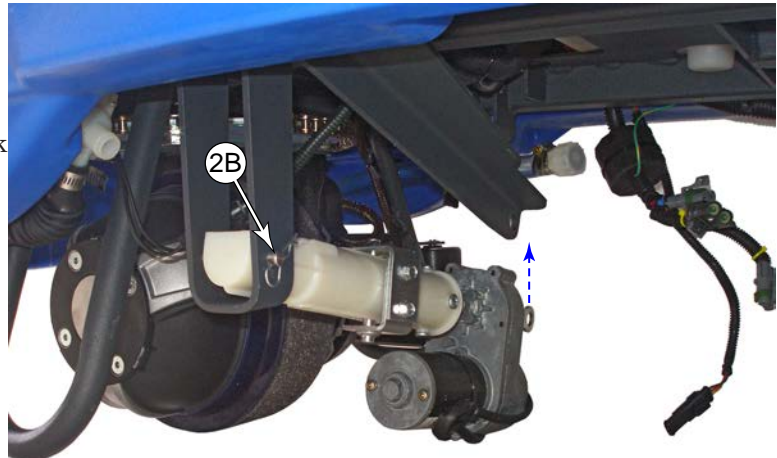
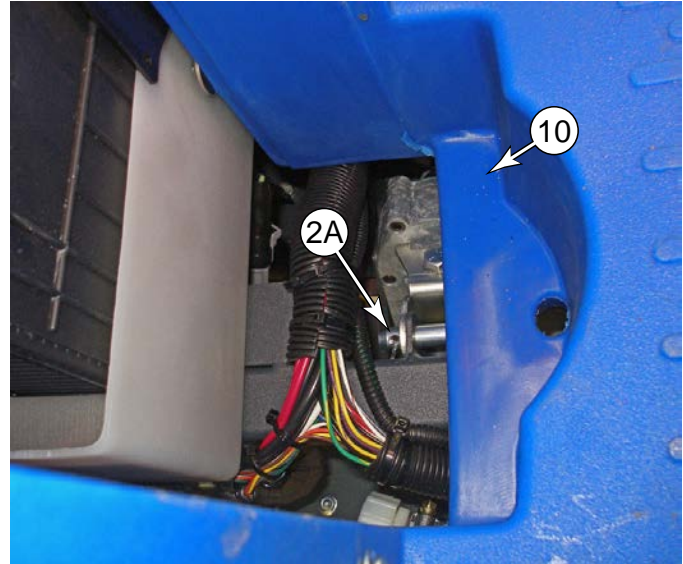

Lead Nut and Spring Orientation

The lead nut and springs need to be oriented as shown in the images below according to the deck type. A quick inspection can be made by removing the four screws (2L), and sliding the end cap (2F) and upper spring toward the motor, to determine if the upper spring is long or short. To reverse the lead nut and springs, complete the following.

1. Remove the two screws (2K), and slide the pin brackets (2J) out of the lead nut.
2. Remove the four screws (2L) that secure the end cap (2F) and slide the spring housing (2C) off the leadscrew.
3. Unscrew the lead nut, and replace the upper spring with the correct spring: Short spring (2E) for Boost and Disk decks, and long spring (2D) for cylindrical decks.
4. Reinstall the lead nut: holes away from the motor for Boost and Disk decks, and holes toward the motor for cylindrical decks.
5. Finish reassembling the actuator, and then complete the [Lift Actuator Limit Adjustment](#) described on page 58.

Boost and Disk Deck Configuration

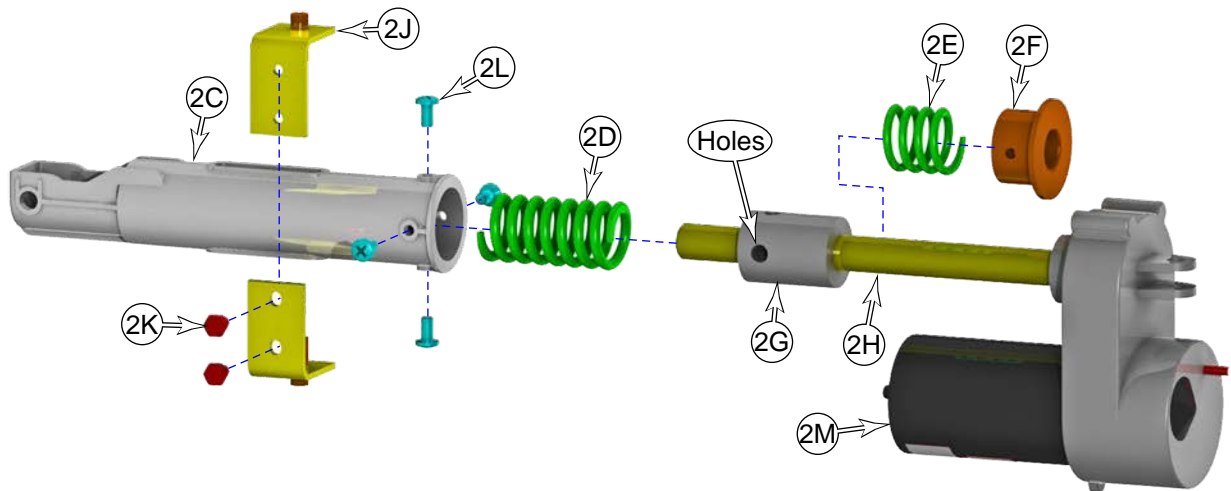

Cylindrical Deck Configuration

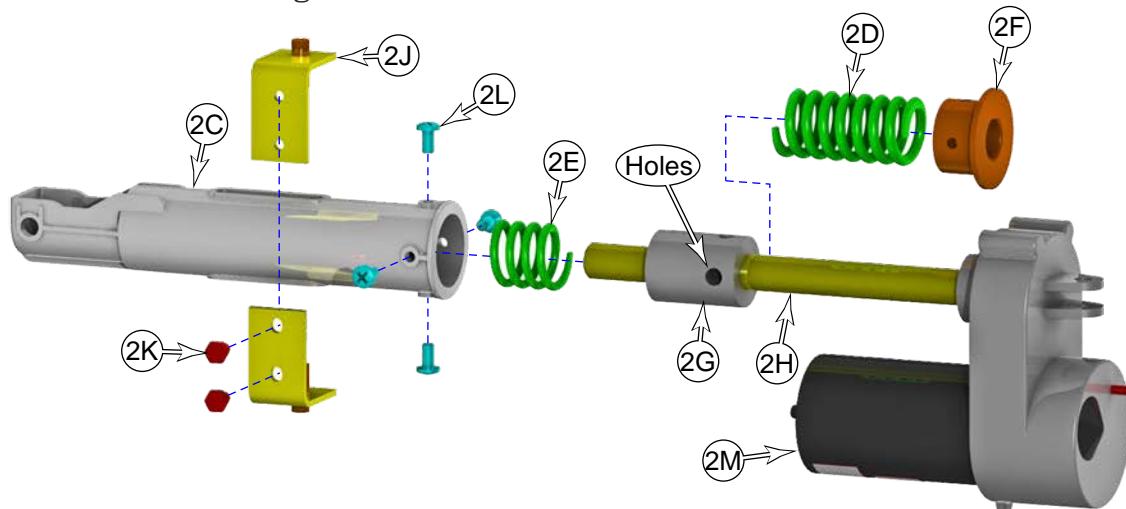

Brush Motor Contactor



Warning: *Disconnect the battery connector before servicing machine. This procedure involves high amperage components. An inadvertent short circuit can damage the components or your tools and equipment.*

1. Turn off the key and disconnect the main battery connector.
2. Remove the [Electrical Panel Cover](#) described on page 37.
3. Remove the incoming and outgoing power cables from the terminal posts (**11A & 11B**).
4. Remove the control wires from the terminal posts (**11C & 11D**).

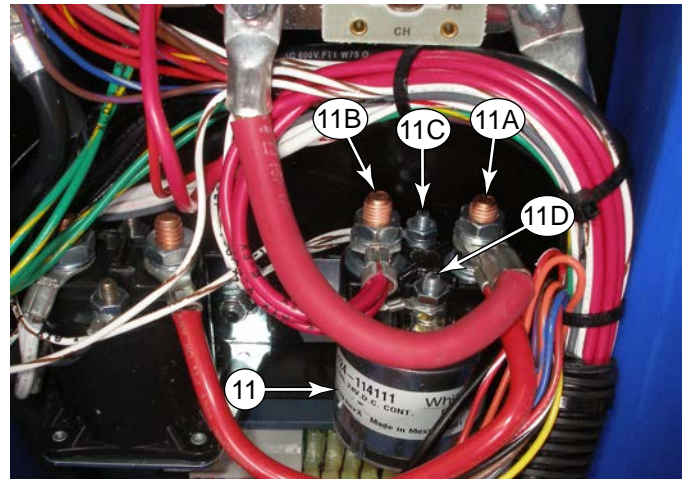

5. Remove the two nuts (**11E**) that secure the contactor to the electrical panel, and remove the contactor.

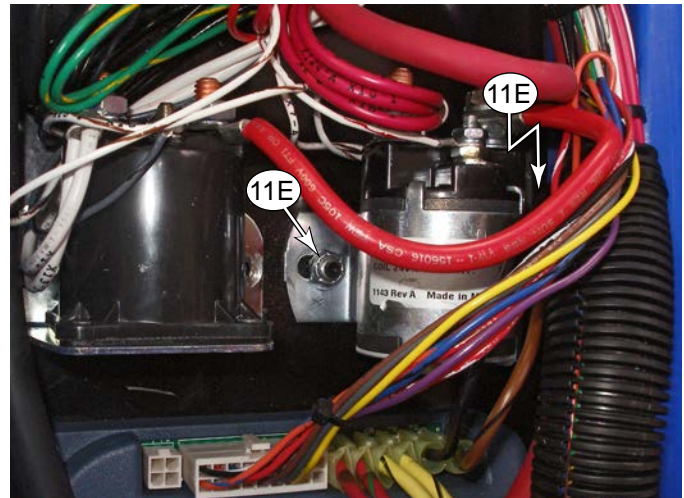

Disc Deck Motor

The same procedure is used for all three disc deck types. However, some decks have 2 motors and some have three.

1. Lower the deck to a neutral position on the floor, and turn the keyswitch to the off position.
2. Remove the [Scrub Deck](#) described on page 59.
3. Remove the discs (**3R**) from the drive hub (**3P**).
4. Remove the bolt (**3Q**) that secures the drive hub to the motor shaft, and remove the hub (**3P**). Take care not to lose the key (**3M**) that aligns the hub and shaft.
5. Remove the 3 nuts (**3J**) that secure the motor to the deck, and remove the motor. Make note of any hose clamp and washer (**3K & 3L**) that may be present and securing the solution line.
6. When replacing the motor, take care to match whether it is a right-hand or left-hand gearbox.

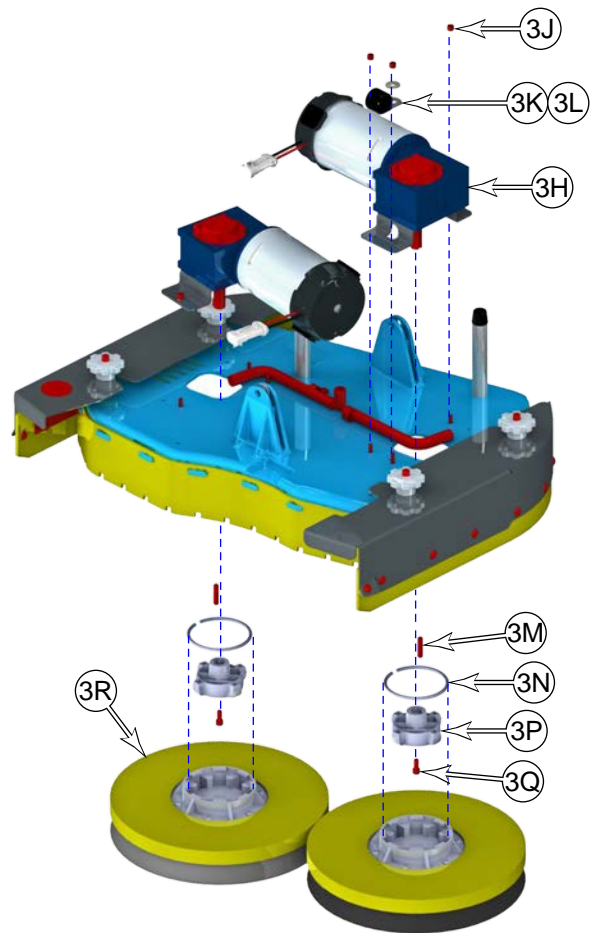

Cylindrical Deck Motor

1. Lower the deck to a neutral position on the floor, and turn the keyswitch to the off position.
2. Remove the [Scrub Deck](#) described on page 59.
3. Remove the screw (**4A**) that secures the drive belt cover (**4B**) to the scrub deck, and remove the cover.
4. Remove the drive belt (**4C**) by walking it off the motor pulley (**4D**), and then off the brush pulley. Hint: When replacing the drive belt, use a screwdriver to assist you walking it back onto the motor pulley, as shown in the image to the right.
5. Loosen the two setscrews (**4E**) that secure the motor pulley (**4D**) to the motor shaft, and remove the pulley.
6. Remove the two bolts (**4G**) that secure the brush motor (**4H**) to the scrub deck, and remove the motor.

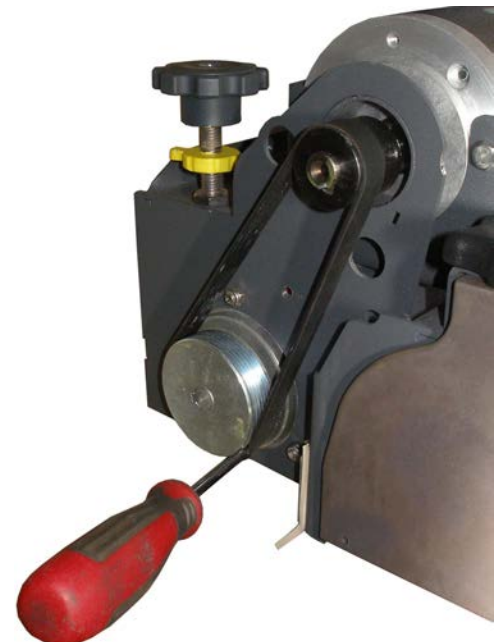
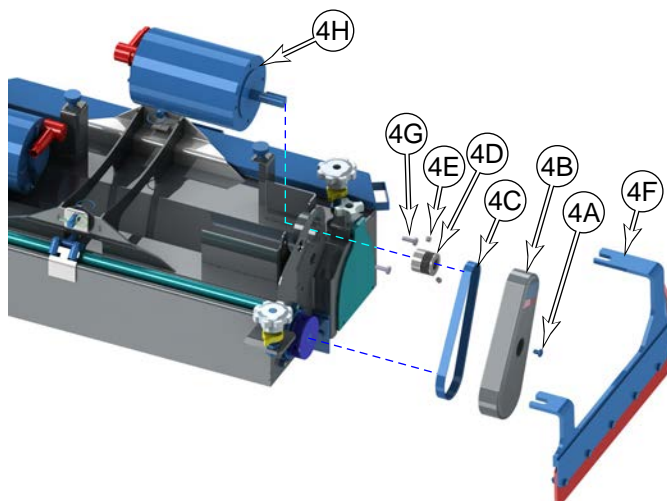

Boost Deck Motor

1. Lower the deck to a neutral position on the floor, and turn the keyswitch to the off position.
2. Remove the [Scrub Deck](#) described on page 59.
3. Loosen the retaining knobs (5E) and remove the side squeeges (5F) from the deck.
4. Remove the 2 bolts (5K) from the limit pins (5L).
5. Remove the 4 nuts (5J) that secure the upper plate (5M) to the isolation mounts, and remove the upper plate. (Tilt the plate at the top of the motor to clear the wiring harness.)
6. Remove the scrub pad from the bottom of the flex plates (5S) (hook and loop fastener).
7. Using a 9/64" hex key, remove the 4 button head cap screws that secure the orbital plate (5R) to the flex plates (5S). Take care to not lose the 4 spacers (5P).
8. Remove the 8 nuts (5N) that secure the isolation mounts to the mid plate (5T), and remove the 2 flex plates (5S) from the mid plate (5T).
9. Remove the retaining bolt (5Z), lock washer (5Y), and eccentric retainer (5X) from the bottom of the motor shaft.
10. Slide the orbital plate (5R) and eccentric lobe (5W) off the motor shaft. Take care not to lose the key (5V).
11. Remove the 4 screws (5U) that secure the motor (5H) to the mid plate (5T), and remove the motor.
12. Make sure to inspect the eccentric bearing before reassembly. If the motor is being replaced, it is likely that the bearing needs replacement too. If the bearing feels rough, or freewheels too easy when spun, it is a sign it is worn.
13. During reassembly, apply a small coating of anti-oxidant compound to the mating metal components of the eccentric drive (motor shaft, eccentric lobe, and bearing).

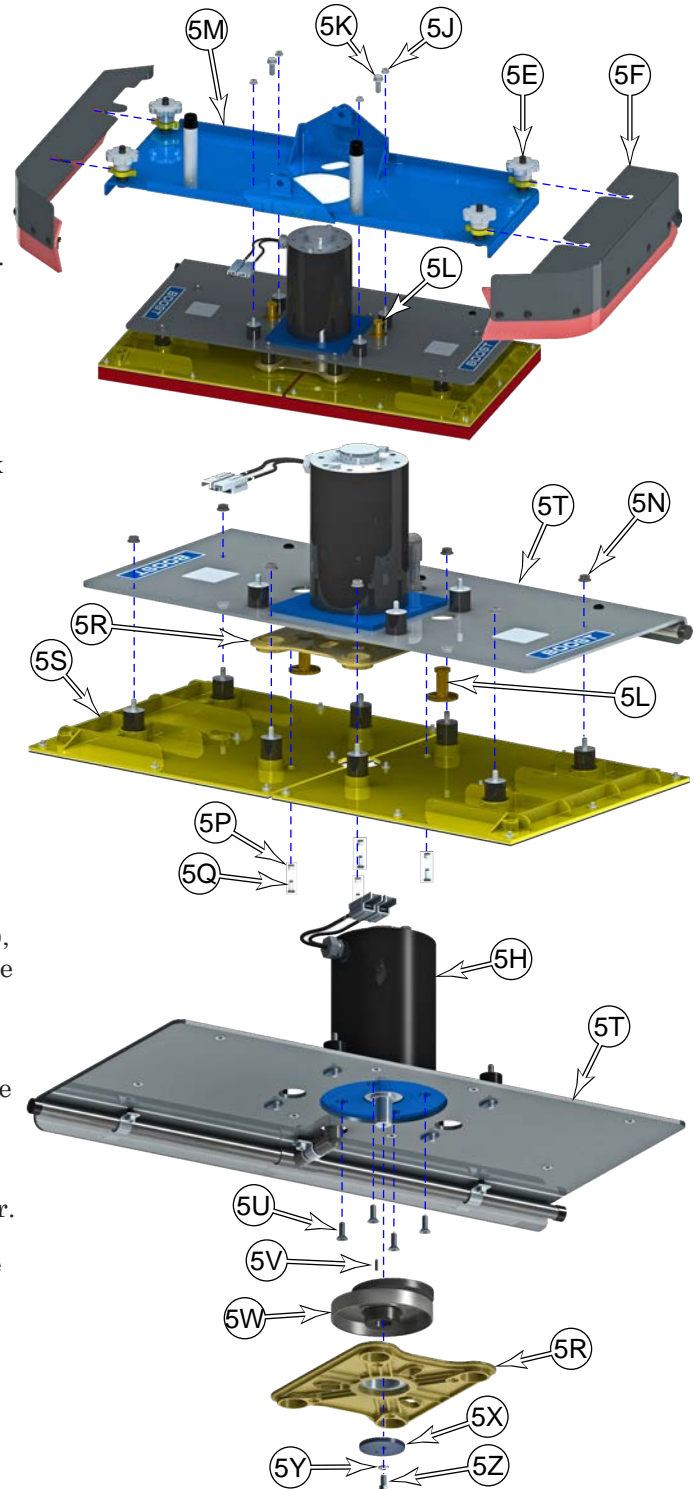

Specifications

Parameter	Range
Brush Contactor Coil Resistance	52.0 Ω
No-Load Motor Amperage	<ul style="list-style-type: none"> • Boost Deck = 9.5-10.4 A • Cylindrical Deck = 7.5 A (total) • 2 Disk Deck = 15.5 A (total) • 3 Disk Deck = 25.0 A (total)
Lift Actuator Amperage	<ul style="list-style-type: none"> • Raising = 1.4 - 2.8 A • Lowering = 0.8 - 1.3 A

Scrub Pressure & Amperage Specifications Chart					
Scrub Mode	Default Pressure Indicator	Deck Type			
		Disc 28"	Cyl. 28"	Disc 34"	Disk 40"
Regular Scrub	1 LED	24 AMPS	20 AMPS	24 AMPS	35 AMPS
Heavy Scrub	2 LED	28 AMPS	27 AMPS	28 AMPS	45 AMPS
Extreme Scrub	3 LED	35 AMPS	34 AMPS	35 AMPS	55 AMPS

Special Tools

The Actuator Power Cord Adapter (1) (PN 56407502) is used to manually control the brush lift actuator.

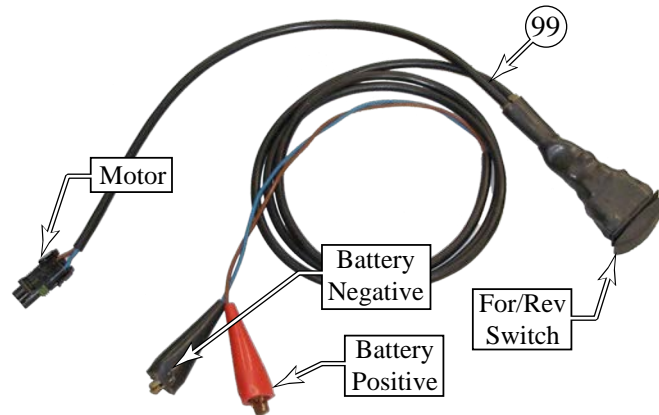

Solution System

Functional Description

The Focus solution tank is incorporated directly into the main body of the machine. A clear tube on the left side of the machine below the fill cap serves as a water level indicator for the tank. At the outlet of the solution tank under the machine, is a manual shutoff valve followed by a serviceable solution filter that prevents debris from entering the rest of the solution system followed by a solution solenoid.

Solution Solenoid

The solution solenoid is located downstream from the solution filter, and activates to allow solution to flow to the scrub deck. To prevent pooling of excess water on the floor when the machine is stationary, the solenoid output from the controller is disabled when the wheel drive is not active. The rate of solution flow is controlled by cycling the solution solenoid on and off at varying duty cycles with a 6-second cycle period.

Solution Indicator	Solenoid On-Time	Solenoid Off-Time
One Bar	2 sec	4 sec
Two Bars	4 sec	2 sec
Three Bars	6 sec	0 sec

Detergent Models

Machines that have on-board detergent mixing use a pump-driven, detergent injection system. The detergent is stored in the removable detergent tank, which has a suction hose from the detergent pump. The detergent pump draws the liquid from the detergent tank and injects it into the solution line between the solution solenoid and the scrub deck. The flow rate of the detergent is controlled by the Main Machine Controller using PWM.

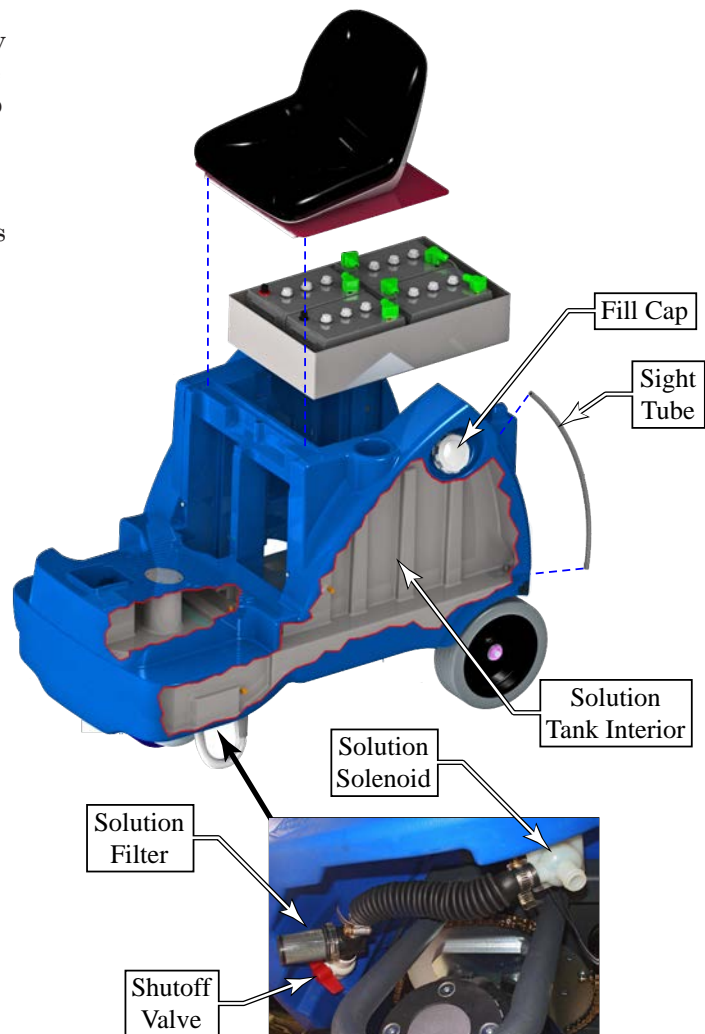

Circuit Overview

Solenoid Valve Circuit

The positive terminal (white/brown wire) of the solution solenoid receives +24V battery power through key switch and E-stop switch. The negative terminal (violet/black wire) of the solution solenoid is connected to the Main Machine Controller at **J3-11**. The solenoid is active when the controller forces the **J1-11** terminal to Battery Negative. The solenoid output is inhibited unless the machine is in motion or pre-wetting is called for.

Detergent Pump

The detergent pump is a small reversible diaphragm pump. The polarity of the pump is reversed to cycle the pump faster. The flow rate of the detergent pump is controlled by PWM at varying rates depending on the desired mixing ratio.

Solution System Schematic

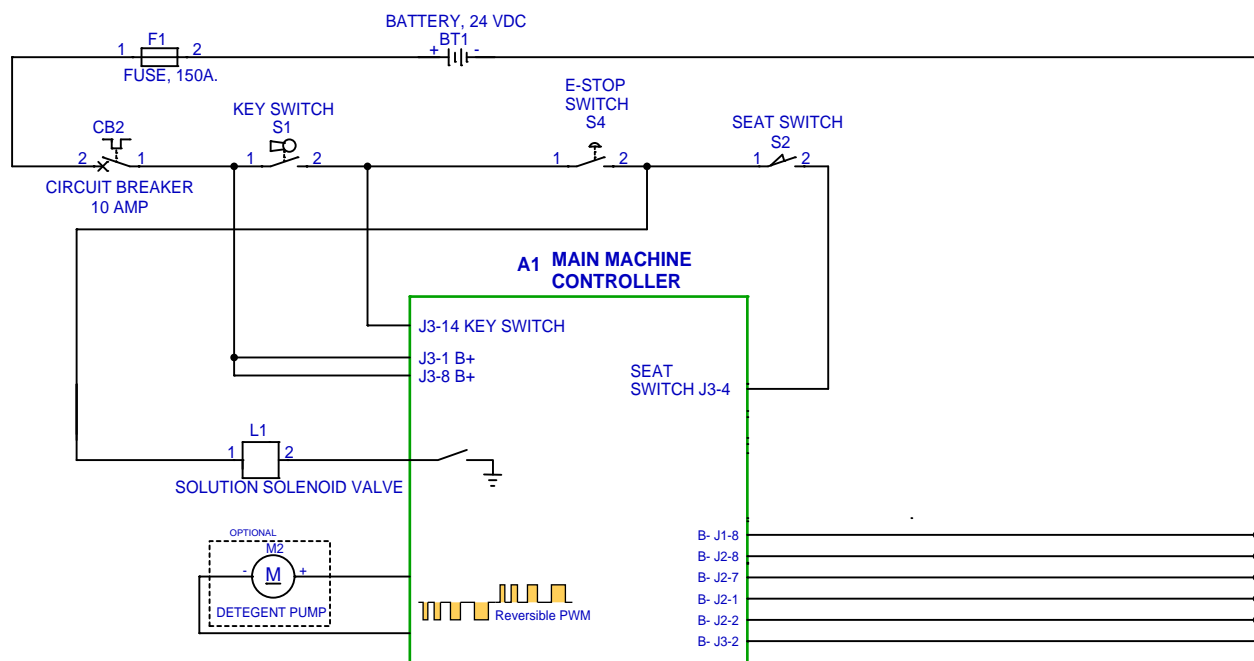

Removal and Installation

Solution Valve, Filter, and Solenoid

The solution valve, filter, and solenoid are located under the front left corner of the machine. Accessing all three components is similar.

- If the solution valve needs servicing, drain the solution tank. Otherwise close the solution valve.
- To replace the solenoid (3), do the following:
 - a. Loosen the hose clamp on the outlet hose to the scrub deck, and remove the outlet hose (not shown).
 - b. Loosen the hose clamp (4) on the inlet flex hose (5), and remove the flex hose.
 - c. Remove the solenoid mounting screw (6), and remove the solenoid.
- To replace the filter body (2A) or the outlet valve (1), do the following:
 - a. Loosen the hose clamp (7) on the outlet flex hose (5), and remove the flex hose.
 - b. Unscrew the filter bowl (2B) from the filter body (2A), and remove the filter and bowl.
 - c. If present, remove the detergent injection line from the tee (8).
 - d. Unscrew the filter body (2A) from the valve (1).
 - e. To unscrew the valve from the solution tank, turn the valve to the open position so the handle is in-line with the fittings.
- During reassembly, clean the pipe threads and reapply thread sealant. Recommended thread sealant is Permatex 80724 or 80726 plastic pipe sealant.

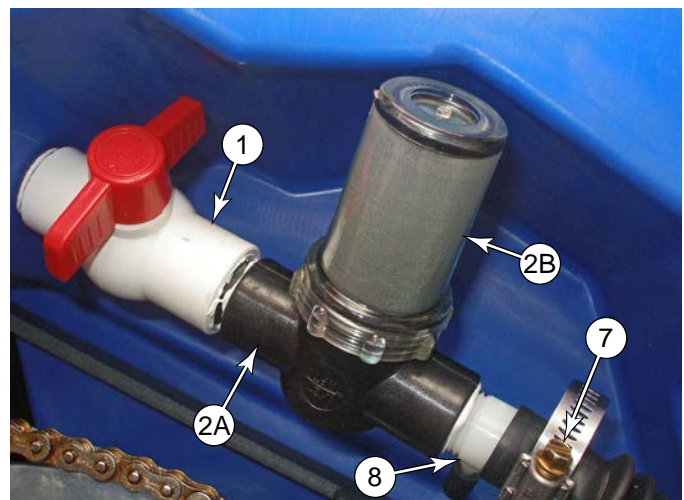
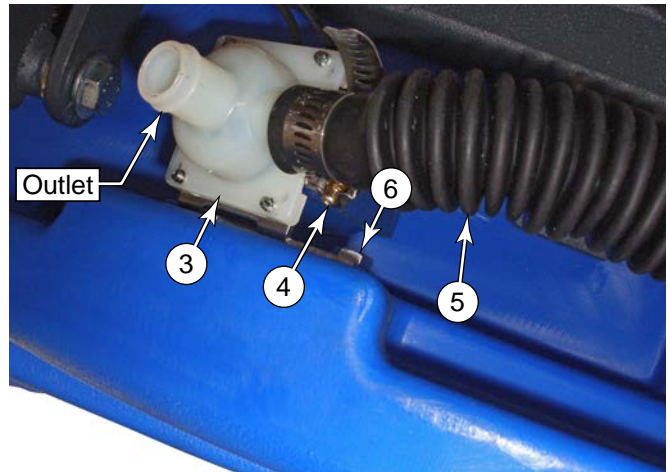
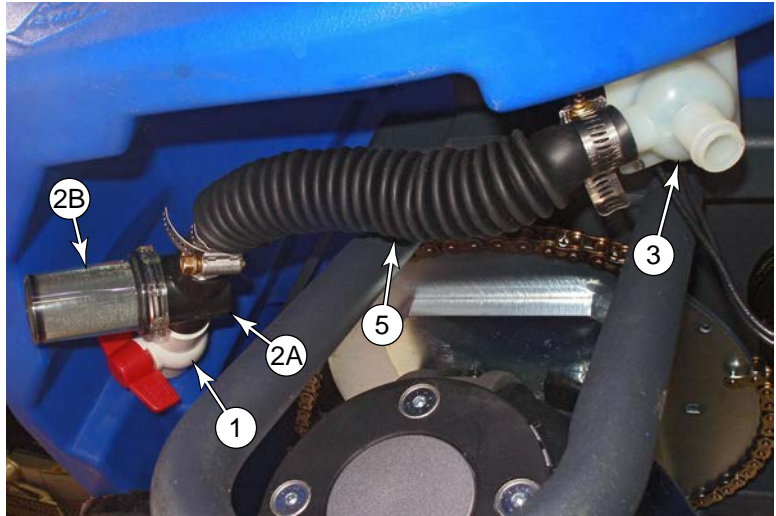

Detergent Pump

1. Turn the key switch to the off position.
2. Remove the detergent bottle from the machine.
3. Make note about which hose is connected to each port of the pump.
4. Make note of which wire is connected to each terminal of the pump.
5. Disconnect the hoses (10 & 11) and wires (12 & 13) from the pump (9).
6. Raise the operator's seat and remove the two screws that secure the pump to the detergent bulkhead, and remove the pump.

Note: Take care when tightening the pump mounting screws. Overtightening can strip the holes in the pump housing.



Specifications

Parameter	Range
Solution Solenoid Resistance	• 33.5 Ω
Detergent Pump Resistance	• 39.9 Ω
Maximum Solution Flow	• 6 L/Min, unrestricted

Squeegee System

Functional Description

The squeegee tool collects wastewater from the floor for the recovery system to lift the water into the recovery tank. The floor squeegee is wider than the swath of the scrub deck to ensure collection of all wastewater from the perimeter of the scrubbing area. The squeegee also pivots to the side to permit operation near walls and to keep the squeegee within the scrubbing path while turning the machine.

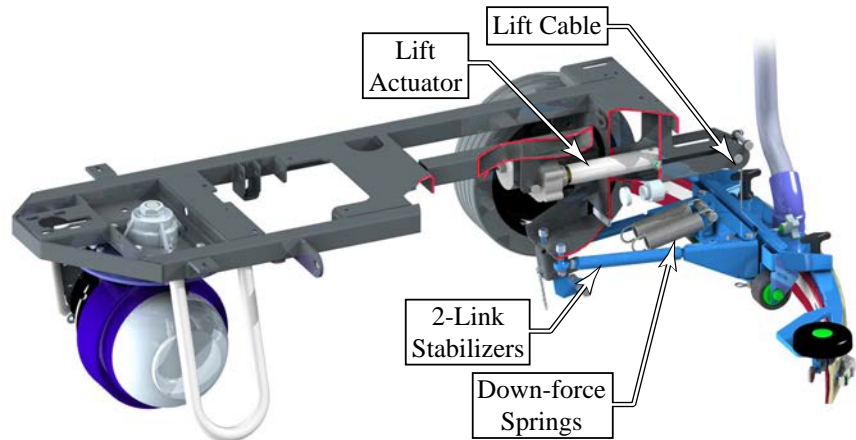

Squeegee Lift Actuator

The squeegee lift actuator operates on a cable that raises the squeegee assembly. When the actuator is not pulling on the cable, the down-force springs press the squeegee to the floor. The upper and lower positions of the squeegee are determined by internal limit switches in the actuator.

Squeegee

The squeegee tool has a front and rear squeegee blade, creating a vacuum area in between where water can be drawn up from the fast moving airflow. The squeegee tool attaches to the lift/pivot assembly with two knobs.

Maintenance and Adjustment

Squeegee Blade Cleaning and Inspection

Periodically clean and inspect the squeegee tool (1) and blades (5&8). Remove the squeegee tool from the pivot/lift assembly by removing the suction hose (2) and loosening the two thumb nuts (3).

Clean the squeegee blades (5&8) and suction area between the blades with soap and water.

Inspect the squeegee blades for nicks, tears, and worn leading edges. If a squeegee blade is worn or damaged, it may be turned around with a fresh edge facing down/forward up to four times before complete blade replacement is required.

When reinstalling the squeegee tool (1) to the pivot/lift assembly, tighten the two thumb nuts (3) only hand tight.

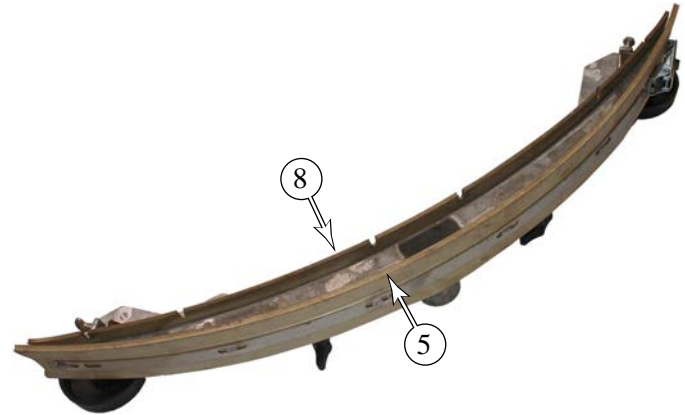
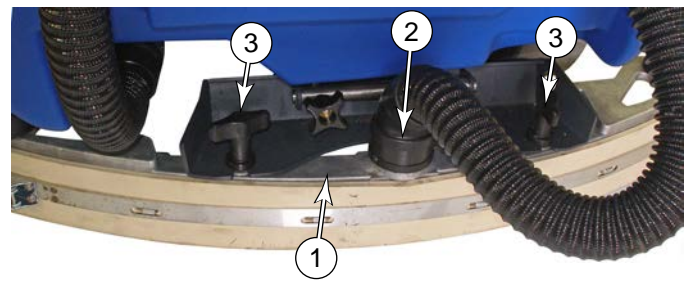

Squeegee Trim Adjustment

The squeegee trim needs to be checked or adjusted whenever the squeegee blades are replaced, or if the squeegee is not fully wiping the floor. Misadjustment symptoms include water streaks at the center or edges of the squeegee path.

1. Park the machine on a flat, even surface and lower the squeegee tool.
2. Inspect/adjust the wheel height to ensure the squeegee tool is resting at the proper level.
3. Examine how the rear squeegee blade is making contact with the floor surface, and inspect for gaps at either the center or edges.
4. Tighten (clockwise) or loosen (counterclockwise) the squeegee trim adjustment knob (19) to level the squeegee across its length.
 - If there is a gap in the center, loosen the adjustment knob.
 - If there are gaps at the outside, tighten the adjustment knob.
 - Make sure the flare of the rear blade is even along the entire length of the blade.

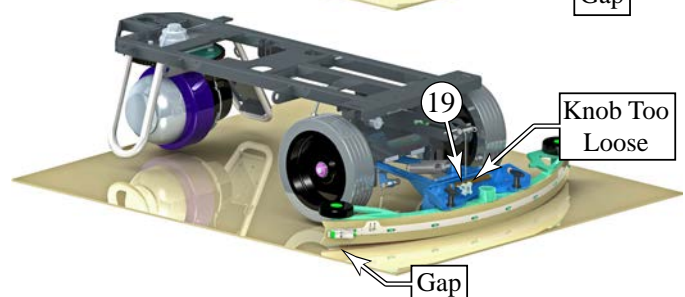
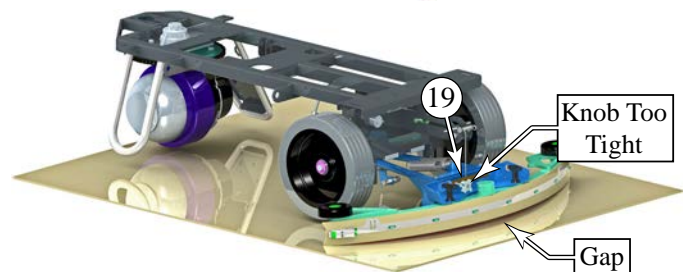
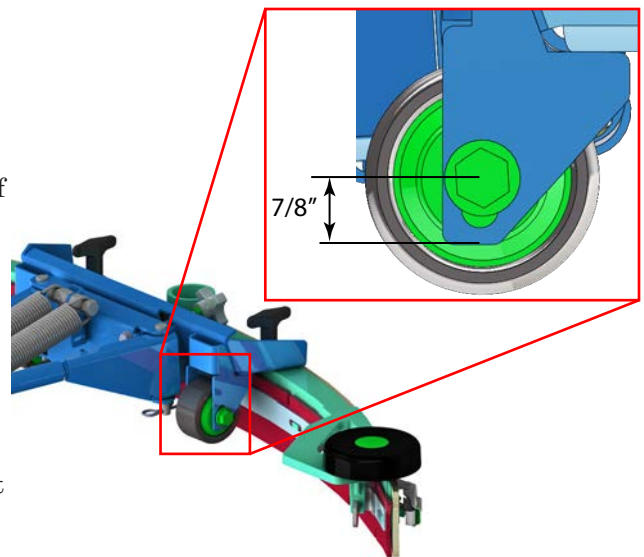

Actuator Limit Adjustment

To protect the actuator from traveling too far, it contains an internal limit switch for maximum travel. This adjustment requires the use of the Actuator Power Cord Adapter (99) (PN 56407502) shown to the right.

This procedure is typically performed as part of replacing the actuator. If the actuator is not already removed from the machine, then remove it following the procedure on page 76.

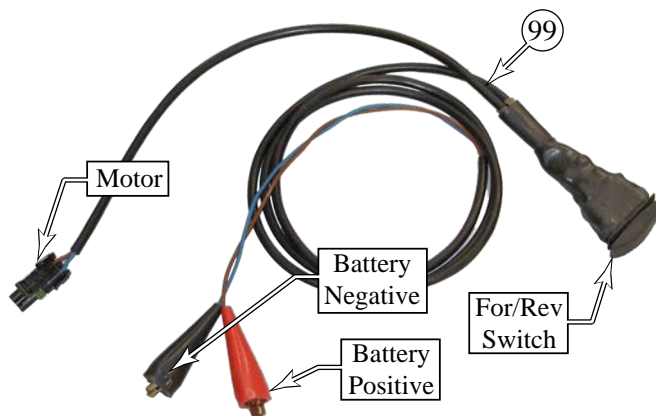

1. Connect the Power Cord Adapter (99) to the positive and negative battery terminals of the Focus II machine. Make sure the adapter is connected so that it receives the full 24 volts.
2. Connect the other end of Power Cord Adapter (99) to the actuator's power connector.
3. While holding the nut housing (18) from turning, press the For/Rev switch on the Adapter (99) to move the nut housing (18) toward the actuator gear housing (17A) until the motor stops (minimum limit switch engaged).
4. Rotate the nut housing (18) until the distance between the spring housing and gear housing (**Housing Distance**) is 5/16", and as necessary, unscrew the nut just enough to make the clevis pin holes (18A) parallel to the gear housing (a drill bit is shown in the photo for clarity).

Important: After the limit is adjusted and until the actuator is back in the machine, make sure not to rotate the nut housing relative to the motor housing.

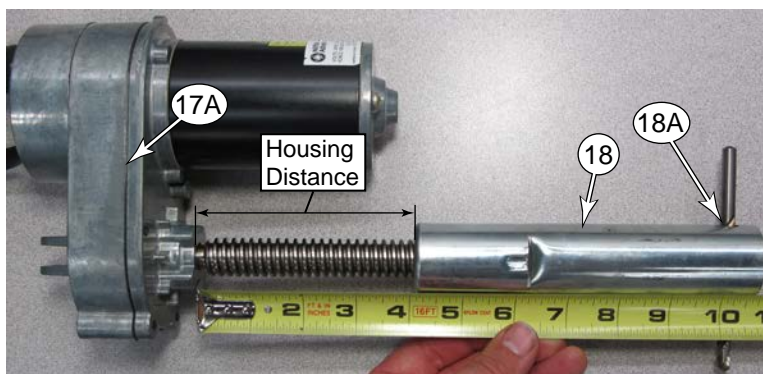

5. While holding the nut housing (18) from turning, press the For/Rev switch on the Adapter (99) to move the nut housing away the actuator gear housing until the motor stops (maximum limit switch engaged).
6. Measure the Housing Distance. If it is not approximately 4", then adjust the lower limit.
 - a. Remove the dust cap (17B) from the top of the gear housing using your fingers or a small screw driver.
 - b. Place a 1/2" socket over the limit adjustment nut to turn the nut, and increase or decrease the lower limit as follows:

Important: Even though the center of the adjustment nut looks like it will accept a screwdriver blade, this is the retainer for the adjustment nut. Do Not try to turn the retainer!

- Each "click" of the adjuster nut changes the Housing Distance by 1/16".
- To increase the Housing Distance, turn the nut clockwise.
- To decrease the Housing Distance, turn the nut counterclockwise.

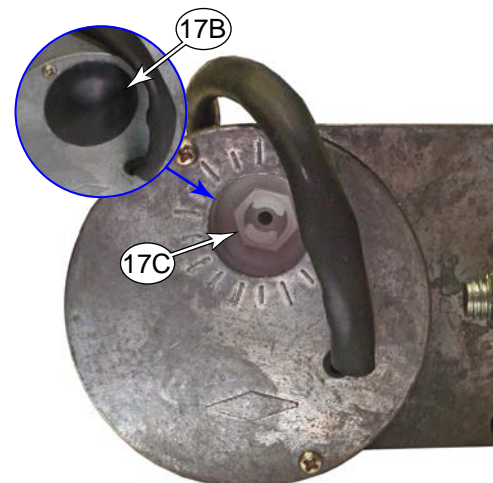

7. Using the Adapter cord (99), move the nut housing back to the approximate position it was in when you removed it from the machine, and reinstall the actuator on the machine.

Removal and Installation

Rear (main) Squeegee Blade Reversal or Replacement

1. Remove the suction hose (2) from the squeegee body (1).
2. Loosen the two thumbscrews (3) that secure the squeegee body (1) to the machine, and remove the squeegee body.
3. Press forward on the latch release (4A) and lift up on the latch handle (4B), and remove the retaining strap (4).
4. Lift the rear squeegee blade (5) off the squeegee body (1).

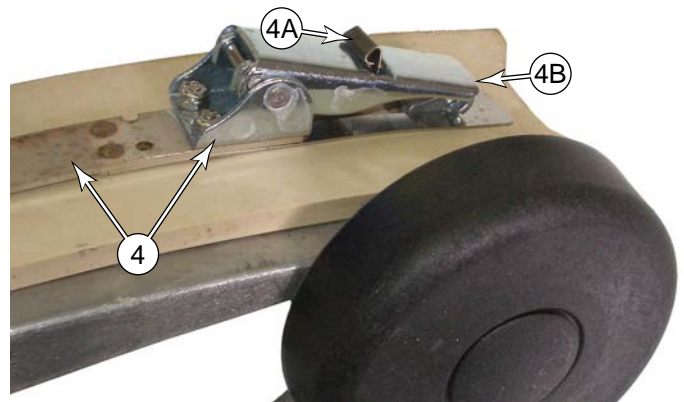
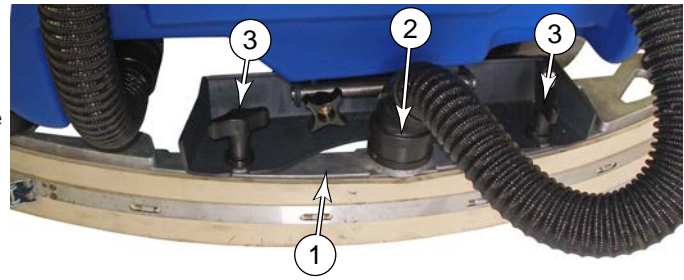

- The squeegee can be rotated and/or flipped 3 times to expose a new edge (4 edges total) to the lower-front. If all 4 edges are worn, replace the squeegee blade (5) with a new one.

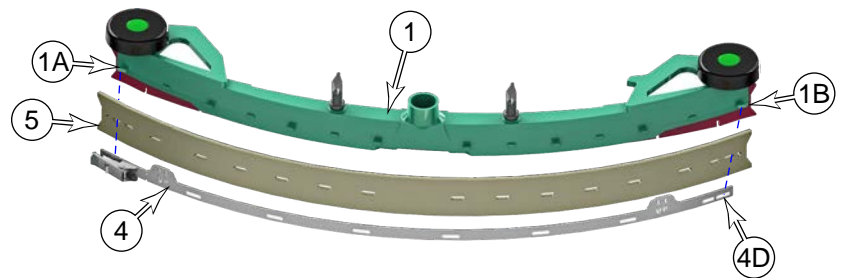

5. To replace the blade (5), align the slots in the blade with the tabs on the squeegee body (1).
6. Hook the last slot (4D) of the retaining strap (4) over the hooked tab (1B) of the squeegee body.
7. Place the latch hook (4C) over the hooked tab (1A) of the squeegee body, and close the latch handle (4B).

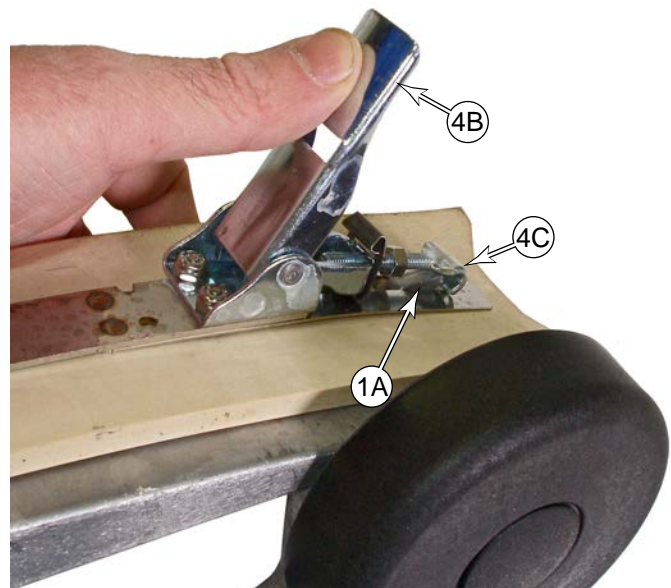

Front Squeegee Blade Reversal or Replacement

1. Remove the suction hose (2) from the squeegee body (1).
2. Loosen the two thumbscrews (3) that secure the squeegee body (1) to the machine, and remove the squeegee body.
3. Loosen the clamping thumbscrew (6) that compresses the retaining strap (7) against the squeegee blade (8) and squeegee body (1).

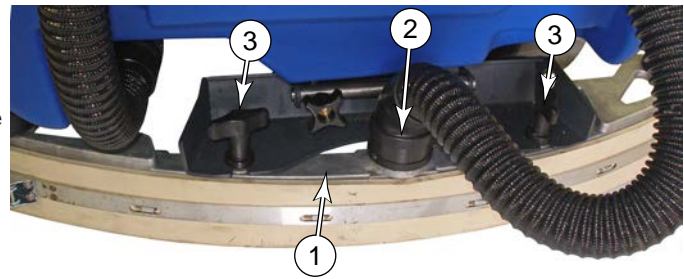

Note: The thumbscrew (6) may be on either the left or right side of the squeegee body.

4. Slide the retaining strap (7) toward the thumbscrew (6), lift it off the tabs of the squeegee body (1), and slide it down to free it from the squeegee body.
5. Lift the front squeegee blade (8) off the squeegee body (1).

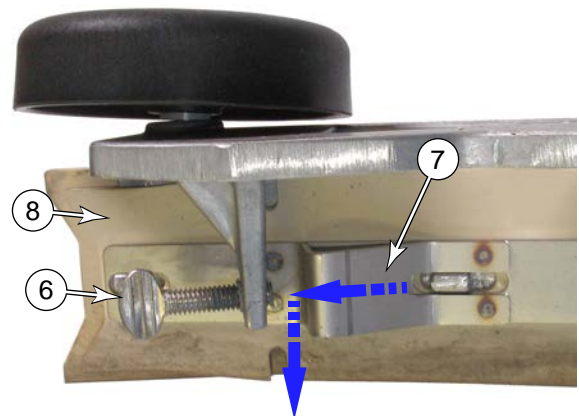

- The squeegee can be rotated and/or flipped 3 times to expose a new edge (4 edges total) to the lower-front. If all 4 edges are worn, replace the squeegee blade (5) with a new one.

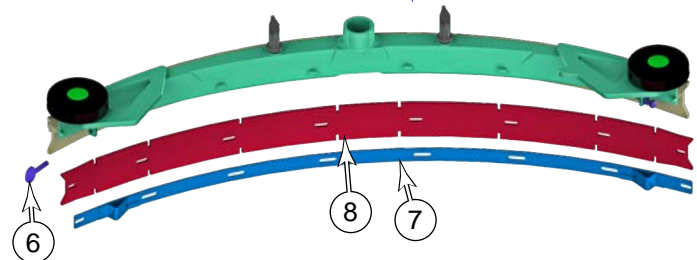

6. To replace the blade (8), align the slots in the blade with the tabs (1C) on the squeegee body (1).
7. Reinstall the retaining strap (7) in the reverse process from removing it.
8. Tighten the thumbscrew (6) to press the retainer against the squeegee blade.
9. Inspect the adjustment clamping screw (9) to ensure it is properly adjusted.

- If the screw is adjusted too far in, the tabs (1C) will be too close to the slots at (7A) and make it difficult to install or remove the retaining strap.
- If the screw is adjusted too far out, the tabs (1C) will be too close to the other end of the slot at (7B) and the clamping thumbscrew (6) will not properly hold the retaining strap.
- When properly adjusted, the tab (1C) should be close to (7B) but not touching, when the thumbscrew (6) is tightened.
- Make sure the jam nut (10) is tightened against the post on the squeegee body.

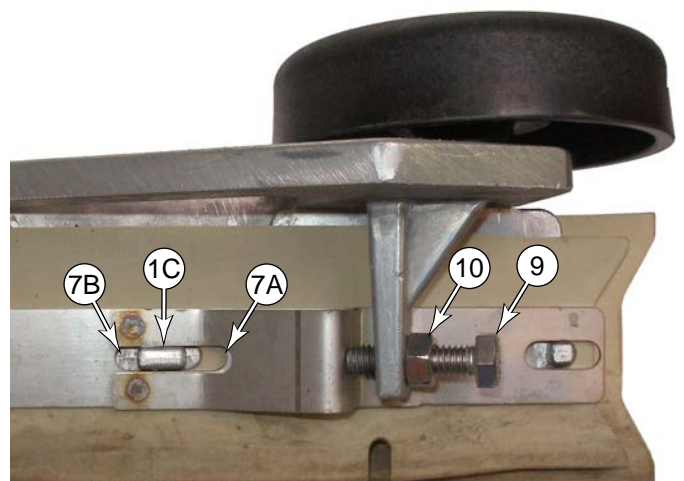

Squeegee Lift Actuator

1. Before turning off the machine, go into the [Service Test Mode](#) described on page 22, and lower the squeegee enough to release tension from the lifting cable.
2. Turn off the machine and disconnect the battery to prevent the squeegee lift from inadvertently being activated.
3. Remove the [Recovery Tank](#) described on page 52.
4. For easier access, you may wish to remove the [Scrub Deck](#) described on page 59.
5. Remove the C-clip (11) from the rear guide pin (12), and remove the pin and lift cable (13).
6. Disconnect the motor cable connector (14).
7. Remove the cotter key (15) from the front guide pin (16), and remove the pin.
8. Slide the lift actuator (17) out toward the front of the machine.

Note: *If the actuator is being removed for maintenance that will not require readjusting the limit positions, then take care not to rotate the nut (18) with respect to the gear housing (17).*

9. For a new actuator or if the nut was repositioned with respect to the gear housing, perform the [Actuator Limit Adjustment](#) described on page 73.
10. Reinstall the actuator on the machine by reversing the procedure steps.

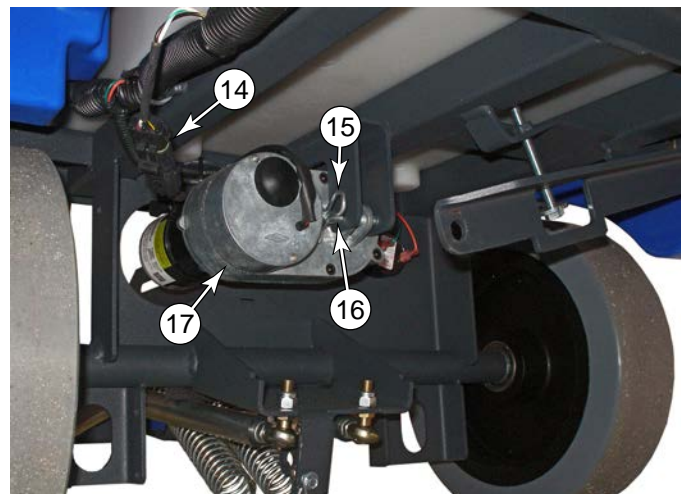
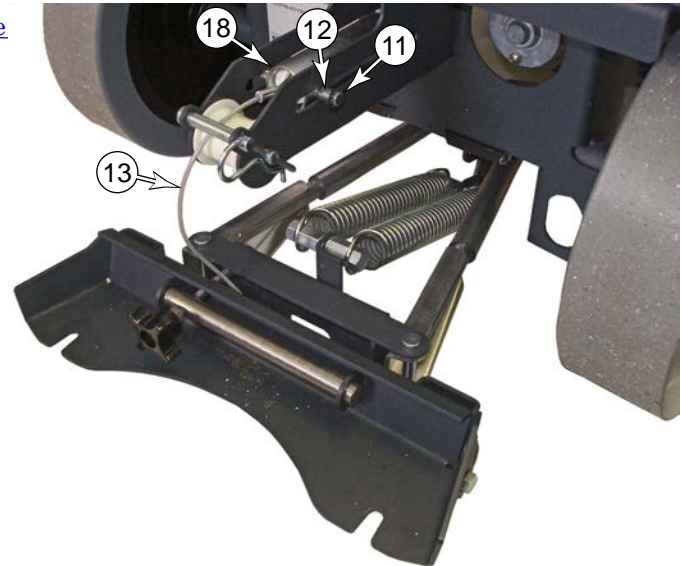

Specifications

Parameter	Range
Squeegee Lift Actuator Amperage	<ul style="list-style-type: none"> • Raising = 2.2 - 3.4 A • Lowering = 2.3 - 2.6 A

Wheel System, Non-Traction

Functional Description

The non-traction wheels are intended to carry the majority of the machine's weight. The wheels are strategically located below the battery compartment and between the recovery and solution tanks. The non-traction wheels are connected directly to the machine's subframe.

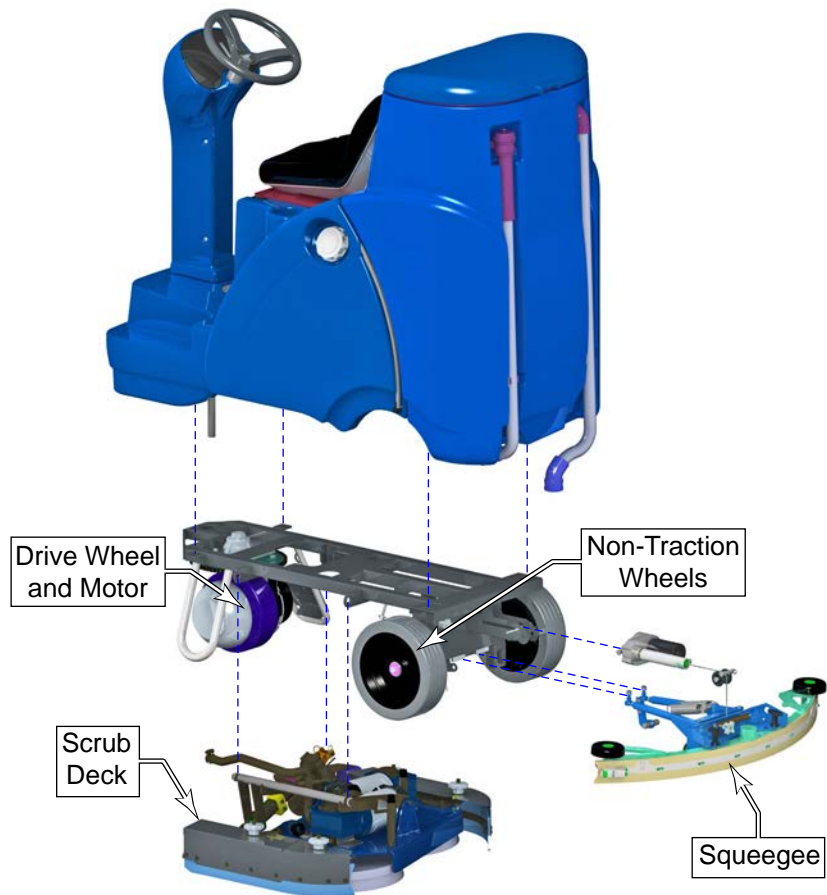

Removal and Installation



Warning: *Never work under machine without safety stands or blocking to support the machine.*

1. To reduce the weight of the machine, drain both the recovery and solution tanks.
2. Jack the rear of the machine and block both sides of the machine at the rear lifting points (5) near the wheels to keep the machine stable and prevent it from rolling.
3. Remove the bolt (2) and washer (3) that secure the wheel to the axle (4), and remove the wheel.

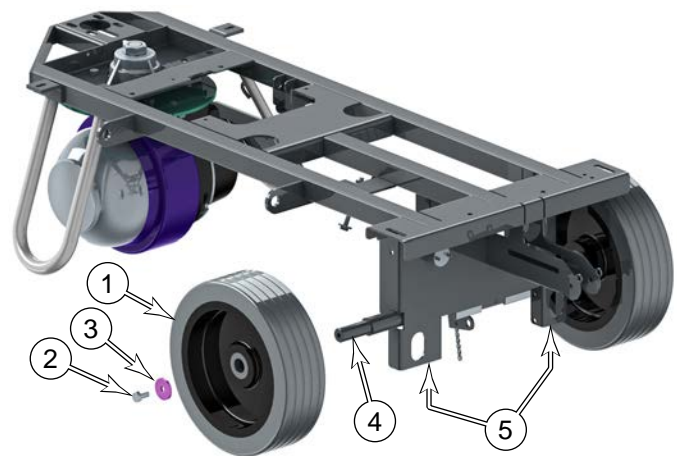

Wheel System, Traction

Functional Description

The drive system of the Focus machine consists of a single drive wheel with an integral motor. The drive wheel connects to the subframe with a rotational bearing and flange to provide steering rotation.

Steering control is made through the steering column that passes through a universal joint to translate the rotation from the angled steering wheel to the vertical shaft and pinion sprocket. The pinion sprocket drives a chain that wraps around the steering sprocket. The steering sprocket has no chain teeth, but the chain is fixed to the sprocket at the ends of the chain using standard master links.

Drive Pedal Sensor

The drive pedal sensor (R1 pot) is a variable resistor connected to the Pin-4 input of the wheel drive controller, with pins 3 and 13 as reference voltages. As the resistance changes, the wheel drive controller increases or decreases drive motor speed.

For the Focus drive system, the drive pedal sensor is **not** set up in a wig-wag configuration, where drive direction is controlled by a single potentiometer. Instead, the forward/reverse function is independently controlled by a separate control line between the Main Machine Controller and the Wheel Drive controller. Moreover, the speed-limit function is also controlled by the Main Machine Controller and transmitted to the Wheel Drive controller on a separate control line.

In this configuration, the drive pedal sensor is a simple resistive circuit that tells the Wheel Drive controller the appropriate percentage of power to provide to the drive motor. The remaining drive functions are controlled by the Main Machine Controller through the Wheel Drive controller.

Speed Limiting Potentiometer

To give the operator better control over the machine in operation, the Wheel Drive controller has a variable maximum speed limit for full pedal deflection of the throttle potentiometer. This task is commonly performed with a physical potentiometer in parallel with the drive pedal potentiometer. However, on the Focus system, this speed limiting function is governed by the Main Machine Controller. The Main Machine Controller contains an electronically controlled, solid state potentiometer to provide this speed limit signal to the Wheel Drive controller.

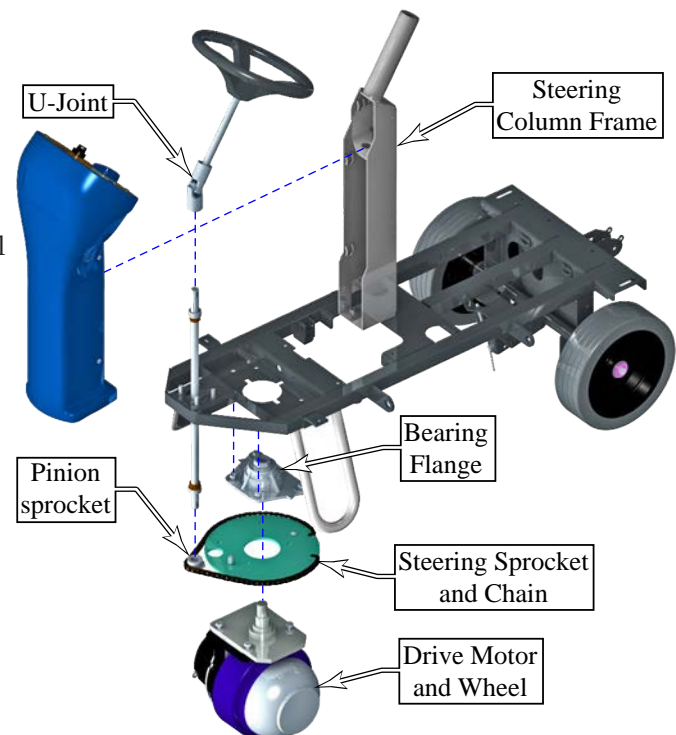

Drive Motor System Function

The drive motor is controlled from a Curtis PMC 1228 controller, which is a pulse-width-modulation speed controller designed specifically for permanent magnet DC motors. Pulse-width-modulation (PWM) is a form of motor speed control that alters the power to a motor by rapidly turning the power on and off. The ratio (also called “duty cycle”) between the On and Off states determines how much power the motor receives. The shorter the “off-time” the closer to full power the motor will receive. This switching occurs so fast (15kHz for this controller) that the motor simply sees it as a reduction in power (voltage) instead of the rapid on/off. PWM is a standard motor control technique because it is easier to turn power all the way on and all the way off, than it is to vary the magnitude of the power. Varying the magnitude would create a lot of heat that would need to be dissipated.

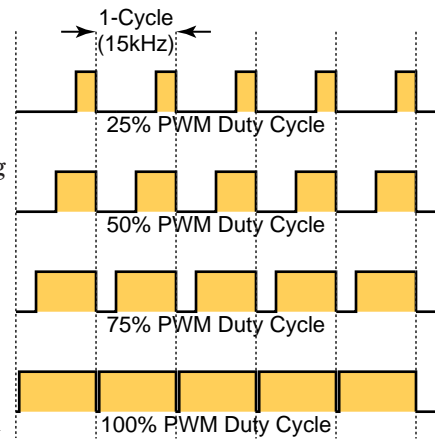

Drive power (**B+**, **B-**) is always present at the speed controller (**A2**) from the battery, but the positive battery input (**B+**) is fused through the circuit breaker (**CB1**) at 70 amps. When the key switch (**S1**), E-Stop (**S4**), and seat switch (**S2**) are closed, 24V control power (enable) is provided to the speed controller via the Brown wire (Pin 5-KSI). Opening any one of these series connected switches will disable the drive controller. (If the on-board battery charger is present, its interlock signal is also in series with these switches.)

The two potentiometers (throttle position and speed limit) control the internal “clock” of the controller, which determines the PWM duty cycle described above. The drive pedal sensor is a physical potentiometer located in the drive pedal. The speed limit potentiometer is solid state, and located within the Main Machine Controller. Forward and reverse directions are controlled by a separate connection from the Main Machine Controller to the Wheel drive controller. The reverse function is active-high. When the reverse line is at low voltage, the drive controller is in the forward direction, and vice versa.

When the drive is active (either forward or reverse) the Wheel controller pulls the “Brake” output (Motion at the Main Machine Controller) to GND. This signal is observed by the Main Machine Controller to indicate that the machine is in motion.

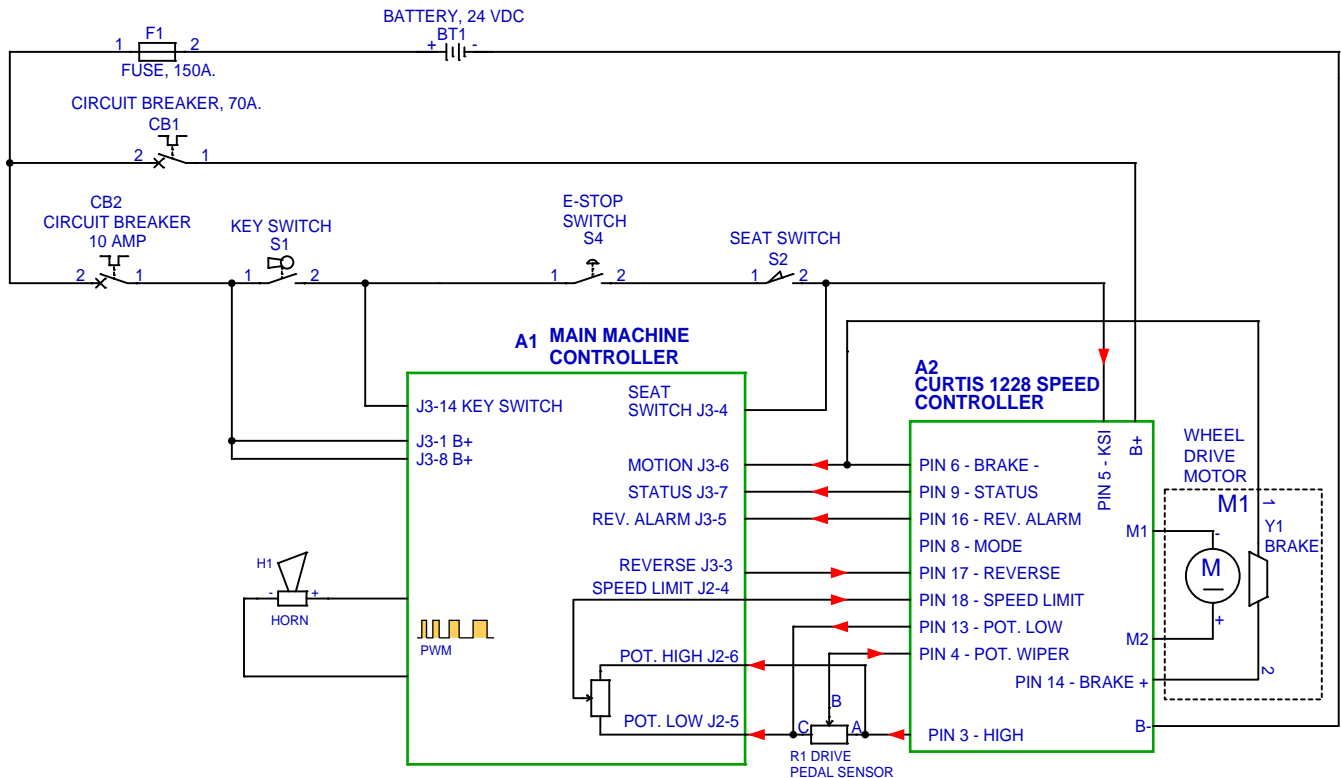

Wheel Drive Controller J10 Pinout Functions

Pin#	Wire Color	Controller Description & Function
1	-	Open not used
2	-	Open not used
3	Yellow	Throttle Pot R1 pot high bias output
4	Gray	Throttle Pot R1 pot wiper input
5	Brown	KSI (key switch input): Battery (+) powers up controller logic circuits
6	Red/Wht	Brake Off: Signifies when the drive system is in motion.
7	-	Open not used
8	-	Open not used
9	Orn/Blu	Status Fault: Speed controller output to main controller
10	-	Open not used
11	-	Open not used
12	-	Open not used
13	Violet	Throttle Pot R1 pot low bias output
14	Orange	Drive wheel brake release: Battery (+) output to the parking brake
15	-	Open not used
16	Blu/Blk	Rev/Alarm Driver output Battery (-) signifies machine in motion.
17	Red/Brn	Incoming reverse control from Main Machine Controller. Battery (+) signifies reverse.
18	Blk/Wht	Speed limit pot wiper input connection.

Troubleshooting

Problem	Cause	Correction
Display LED panel shows an error 03 fault code.	Drive controller problem	<ul style="list-style-type: none"> Refer to the Wheel Drive Controller Error Codes described on page 82
Wheel drive motor will not run in either forward or reverse.	Wheel drive motor circuit breaker (CB1) tripped	<ul style="list-style-type: none"> Reset the 70A circuit breaker
	Control circuit, circuit breaker (CB2) tripped	<ul style="list-style-type: none"> Reset the 5A circuit breaker
	Defective wheel drive motor	<ul style="list-style-type: none"> Check motor connections Inspect motor brushes Replace motor
	Throttle potentiometer (R1) problem	<ul style="list-style-type: none"> Make sure the pedal is in the neutral position and cycle the keyswitch Inspect the potentiometer wires and mechanical linkage
	Drive controller problem	<ul style="list-style-type: none"> Check the Status LED for a fault code and refer to the Wheel Drive Controller Error Codes described on page 82
	Brake failure	<ul style="list-style-type: none"> To test for brake failure, manually release the brake lever as described on page 8 and test the drive motor again. Check for broken or disconnected brake wires. Measure the resistance of the brake. It should be approximately 25 ohms.
Wheel drive motor will run in only one direction but not the other	Reverse control problem	<ul style="list-style-type: none"> Inspect the reverse wire (red/brn). A broken wire will leave the machine in forward-only. Check the voltage of the Reverse output (J3-3) at the Main Machine Controller. If the voltage does not change, replace the controller. Check the voltage of the Reverse input (pin 17) at the Wheel controller. If the voltage does change, then replace the Wheel controller.
Machine rolls (no brake) when not in drive mode	Electrical Problem	<ul style="list-style-type: none"> Disconnect the main battery connection. If the brake engages, then it is an electrical problem. <ul style="list-style-type: none"> Inspect the Red/Wht brake wire for a short to ground. Cycle the key switch, E-stop, or seat switch. If the brake does not engage, replace the Wheel controller. Cycle the key switch, E-stop, or seat switch. If the brake does engage, it is likely the throttle position sensor.
	Mechanical Problem	<ul style="list-style-type: none"> Disconnect the main battery connection. If the brake still does not engage, then it is a mechanical problem. <ul style="list-style-type: none"> Inspect the manual release lever for obstruction. Repair or replace the brake module.

Wheel Drive Controller Error Codes

The Wheel drive controller (A2) communicates error codes with Main Machine Controller (A1) through the Status output of the Wheel controller. When the Wheel controller presents an error to the Main Machine Controller, the display will indicate an “03” error designated as a drive controller error, and the Detergent LED (R) will flash out the 2-digit error code number. The LED will flash a number of times representing the first digit, then a short pause before flashing a number of times representing the second digit, and then a longer pause before repeating the sequence. There may be multiple faults, but only one fault is indicated at a time.

Error codes can also be read using the [Curtis 1311 Programmer PN 56409441 described on page 93](#)

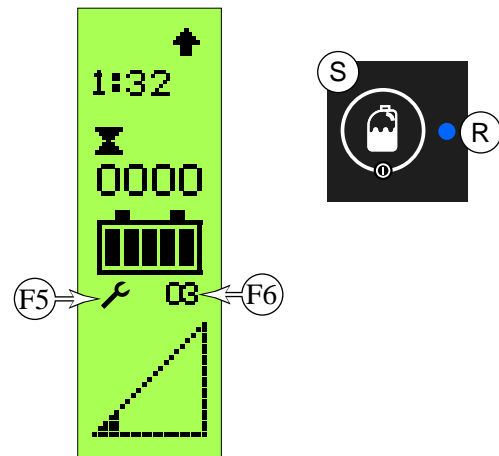

Status Led Fault Codes		
Code	Programmer Display / Explanation	Possible Cause
1,1	THERMAL CUTBACK Over/under-temperature cutback	<ul style="list-style-type: none"> • Temperature >92°C (206°F) or < -25°C (-13°F) • Excessive load on vehicle • Operation in extreme environments • Electromagnetic brake not releasing
1,2	THROTTLE FAULT 1 Throttle fault	<ul style="list-style-type: none"> • Throttle input wire open or shorted • Throttle pot defective • Wrong throttle type selected
1,3	SPEED LIMIT POT FAULT Speed limit pot fault	<ul style="list-style-type: none"> • Speed limit pot wire(s) broken or shorted • Broken speed limit pot
1,4	LOW BATTERY VOLTAGE Battery voltage too low	<ul style="list-style-type: none"> • Battery voltage <17 volts • Bad connection at battery or controller
1,5	OVERVOLTAGE Battery voltage too high	<ul style="list-style-type: none"> • Battery voltage >36 volts • Vehicle operating with charger attached • Intermittent battery connection
2,1	MAIN OFF FAULT Main contactor driver Off fault	<ul style="list-style-type: none"> • Main contactor driver failed open
2,3	MAIN CONT FLTS Main contactor fault	<ul style="list-style-type: none"> • Main contactor welded or stuck open • Main contactor driver fault • Brake coil resistance too high
2,4	MAIN ON FAULT Main contactor driver On fault	<ul style="list-style-type: none"> • Main contactor driver failed closed
3,1	PROC/WIRING FAULT Fault present for >10 sec.	<ul style="list-style-type: none"> • Misadjusted throttle (pedal depressed at key-on) • Broken throttle pot or throttle mechanism • The keyswitch must be cycled before this fault can clear
3,2	BRAKE ON FAULT Brake On fault	<ul style="list-style-type: none"> • Electromagnetic brake driver shorted • Electromagnetic brake coil open
3,3	PRECHARGE FAULT Precharge fault	<ul style="list-style-type: none"> • Low battery voltage • Throttle engaged when KSI (keyswitch input) turned on
3,4	BRAKE OFF FAULT Brake Off fault	<ul style="list-style-type: none"> • Electromagnetic brake driver open • Electromagnetic brake coil shorted

Status Led Fault Codes		
3,5	HPD HPD (High Pedal Disable) fault	<ul style="list-style-type: none"> Improper sequence of throttle and KSI (keyswitch input) Misadjusted throttle pot
4,1	CURRENT SENSE FAULT Current sense fault	<ul style="list-style-type: none"> Short in motor or in motor wiring Controller failure The keyswitch must be cycled before this fault can clear
4,2	HW FAILSAFE Motor voltage fault (hardware failsafe)	<ul style="list-style-type: none"> Motor voltage does not correspond to throttle request Short in motor or in motor wiring Controller failure The keyswitch must be cycled before this fault can clear
4,3	EEPROM FAULT EEPROM fault	<ul style="list-style-type: none"> EEPROM failure or fault The keyswitch must be cycled before this fault can clear
4,4	POWER SECTION FAULT Power section fault	<ul style="list-style-type: none"> EEPROM failure or fault Short in motor or in motor wiring Controller failure The keyswitch must be cycled before this fault can clear

Removal and Installation

Drive Controller



Warning: Disconnect the battery connector before servicing machine.

Note: Drive controllers are factory pre-programmed for the machine. Use only factory authorized replacement controllers.

- Turn off the key and disconnect the main battery connector.
- Remove the [Electrical Panel Cover](#) described on page 37.
- Disconnect the Logic cable connector (3) from the **J10** connector on the drive controller (1).
- Remove the four motor wires (4 & 5) from the drive controller terminals. Note the color coding for later replacement.
- Remove the positive (7) and negative (6) battery wires from the controller. Note the color coding for later replacement.
- Remove the two screws (2) that secure the drive controller (1) to the electrical panel, and remove the drive controller.

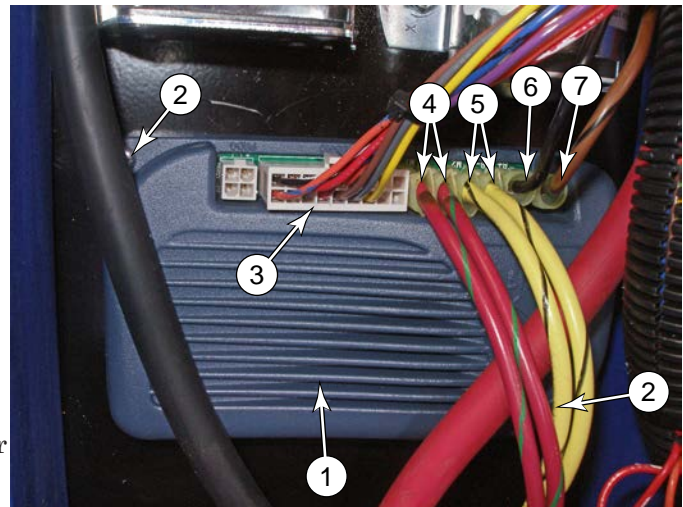

- After replacement, test the machine drive functions in an open area to ensure proper operation.

Drive Wheel Assembly



Warning: Disconnect the battery connector before servicing machine.



Warning: Never work under machine without safety stands or blocking to support the machine.

The drive motor comes out of the machine as an assembly, including the steering chain disk (10) and steering spindle (9). The bearing hub (12) remains within the machine, as the mounting bolts (14) are not accessible without removing the solution tank.

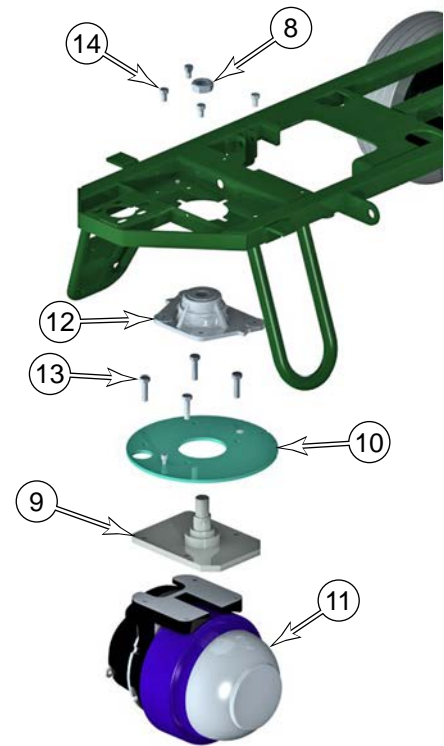

1. Turn off the key and disconnect the batteries.
2. To reduce the weight of the machine, drain both the recovery and solution tanks. To lower the center of gravity of the machine, you may even choose to remove the recovery tank from the machine.
3. Block both sides of the machine at the rear lifting points (15) to keep the machine stable and prevent it from rolling. To prevent tipping, it is also a good idea to chain the machine down at the rear lifting points.
4. Raise the front of the machine by jacking at the center front flat surface of the solution tank.
5. If necessary, block the front of the machine at the forward anchor points (16) so the jacking device can be removed for easier access to components. (The machine will be lowered and re-raised later in the procedure.)

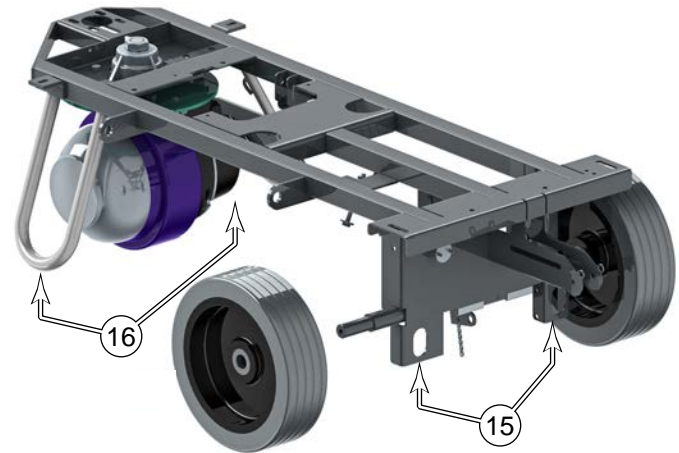

6. Remove one or both master links (23) from the steering chain, and either remove the chain completely, or free the chain from the steering pinion gear (45).



7. Turn the steering wheel to the left so that the motor junction box (18) is easy to access.
8. Remove the two mounting screws (17) that secure the junction box cover, and remove the cover.

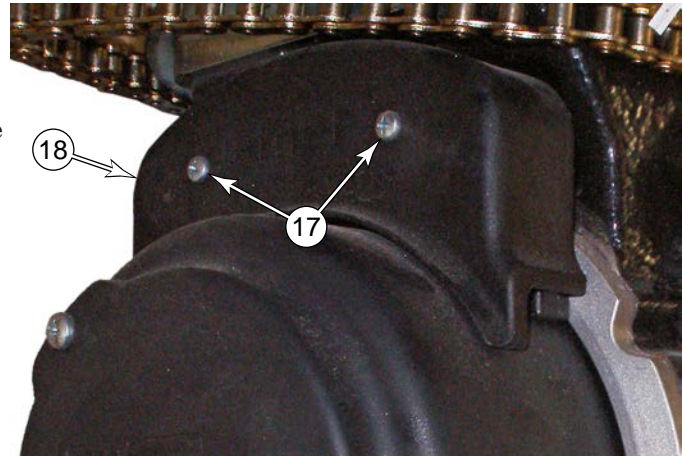

9. Remove the two Yellow/Black power wires from the left terminal (19), and the two Red/Green power wires from the right terminal (20).
10. Remove the Red/White and Orange brake wires from the small terminals (21) and (22).
11. Remove the cable clamp from the underside of the chain disk (10), and free the motor wires from the assembly.

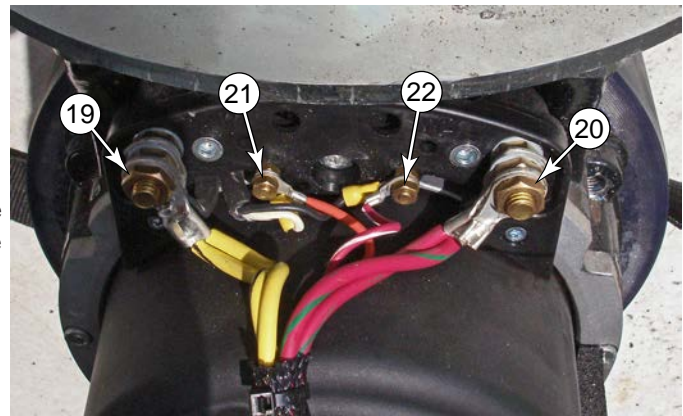

12. Lower the machine back down to the floor.
13. Remove the plastic cap from the solution tank above the spindle nut (8).
14. The drive wheel assembly is heavy. Make sure the machine is lowered back to the floor first, and then remove the spindle nut (8) using a 1⁷/₁₆" socket.
15. While guiding the drive wheel assembly out of the bearing block, raise the front of the machine by jacking at the center front flat surface of the solution tank.
16. Block the front of the machine at the forward anchor points (16) so the jacking device can be removed.

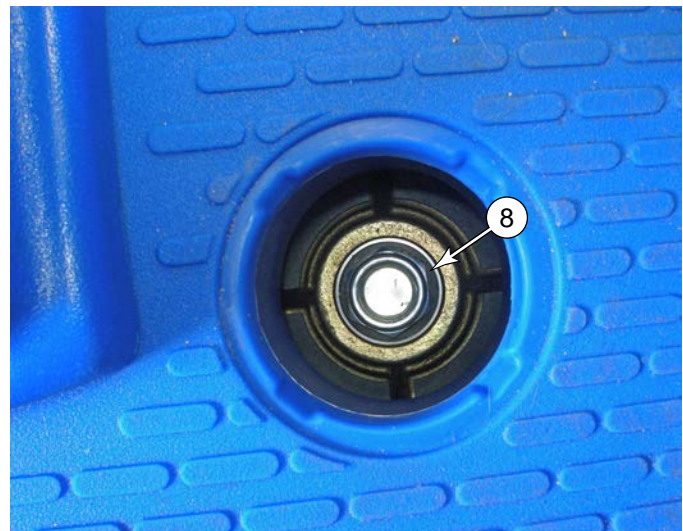

17. Remove the drive wheel assembly from the machine.

If other procedures are required for the drive system, complete them at this time. As applicable, refer to:

- [Drive Motor, Brushes, and Electromechanical Brake](#) described on page 87
- [Drive Tire](#) described on page 89

Reassembly Notes

Any time the drive wheel assembly is removed, it is a good practice to inspect and repack the steering spindle bearings. This will also require replacing the seal (24).

1. Using a screwdriver, pry the seal out of the steering plate. Discard the seal.
2. Remove the thrust bearing cone (25) and clean the old grease from the cone and also from the upper bearing (27), which is not removable.
3. Inspect the bearings and cup (26) for wear and replace if necessary.
4. Repack the bearings with axle grease.
5. Replace the old seal with a new seal.
6. Wipe off accumulated grease and debris from the steering spindle (28).
7. When tightening the steering spindle nut (8), torque the nut to 20 ft-lbs.
8. During reassembly, inspect/adjust the steering chain tension as described on [page 91](#).



Drive Motor, Brushes, and Electromechanical Brake

Removing the drive motor requires the drive wheel assembly to be removed from the machine so it can be stood on-end, to prevent the gear oil from leaking out of the gear box.

Replacing the electromechanical brake requires removing the motor because the wire passes through the motor housing flange. However, the brake disks can be inspected without removing the drive assembly from the machine.

1. Remove the [Drive Wheel Assembly](#) described on page 84.
2. Remove the two screws (29) that secure the motor cover (30), and remove the cover.

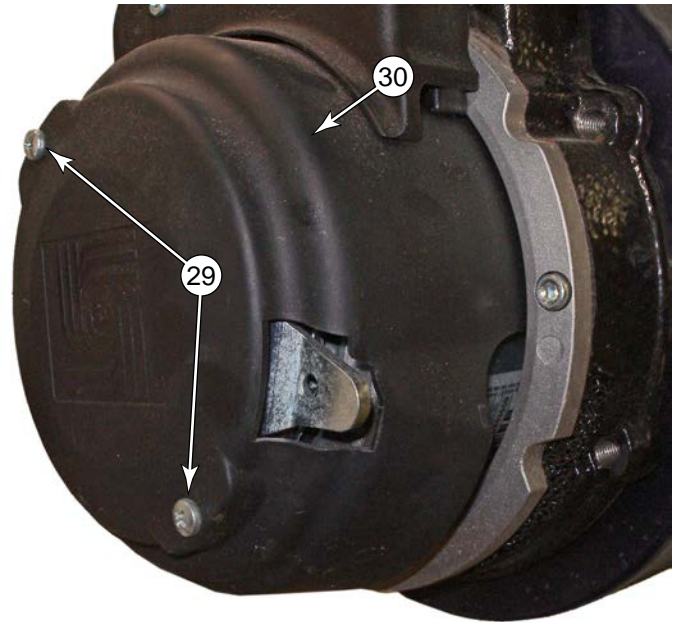

3. Using a 5mm hex key, remove the four screws (31) that secure the motor to the drive wheel assembly.
4. Make sure the motor is facing up to prevent oil from dripping out of the gearbox, and lift the motor out of the drive assembly.
5. Place a clean rag over the opening to the gearbox (32) to prevent debris from entering the gearbox while the motor is removed.

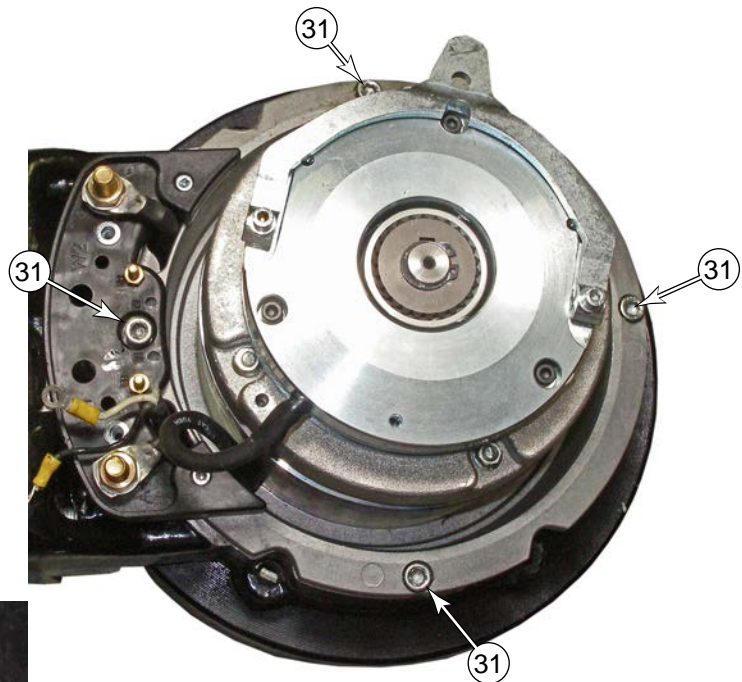

Carbon Brushes

6. Remove each of the 4 brushes (33) from the motor and replace them with new brushes.
7. Remove the nut (34) from the brush terminal, and remove the brush wire. Note that 2 of the brushes also have a large incoming power wire (36) on their terminal.
8. Slide the pressure spring (35) off the carbon portion of the brush, and slide the brush out of the holder.
9. Replace each brush in the reverse procedure.

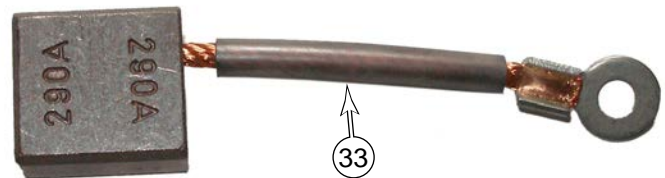
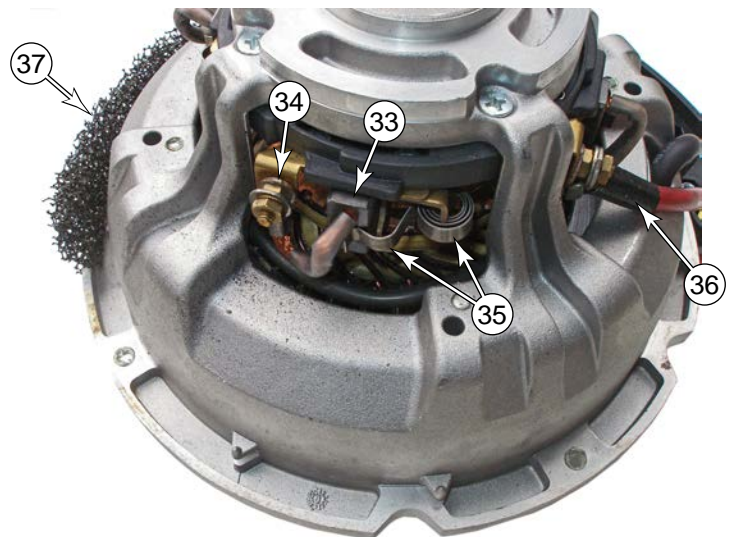

Electromechanical Brake

10. Remove the three screws (34) that secure the brake module (35) to the motor.
11. Free up the brake wire from the motor housing, and remove the brake.
12. During replacement, use a screw driver (37) to hold the brake release lever (36) raised. This will allow the spline gear to float while you realign the mounting screws (34).

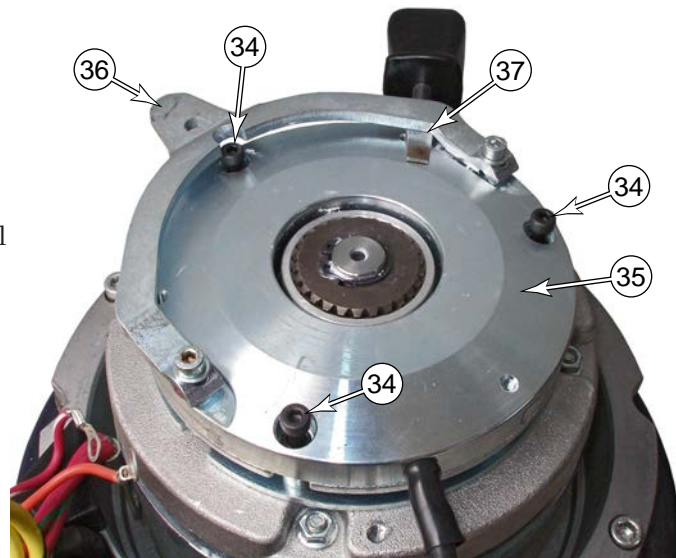

Reassembly Notes

13. Inspect the gear oil. If the gear oil is dirty or some has spilled out, then it must be changed. Due to the configuration of the gearbox, there is no way to check the oil level except to empty the oil and refill it.

When changing the gear oil use 4.6 oz (130 g) of Mobilgear 600 XP 150 or AGIP BLASIA 150 gear oil.

14. Make sure the two vent filters (37) are clean and in place, and then insert the motor back into the gearbox. Take care not to damage the gearbox seal.
15. After reassembling the machine, with the drive wheel off the ground, exercise the drive motor to help break in the brushes.

Drive Tire

Replacing the drive tire (metal wheel with urethane tire) requires the tire pulling kit (56422174). The drive tire may be replaced without removing the drive assembly from the machine, but you may find it easier to remove the [Drive Wheel Assembly](#) described on page 84.

1. To reduce the weight of the machine, drain both the recovery and solution tanks. To lower the center of gravity of the machine, you may even choose to remove the recovery tank from the machine.
2. Block both sides of the machine at the rear lifting points (15) to keep the machine stable and prevent it from rolling. To prevent tipping, it is also a good idea to chain the machine down at the rear lifting points.
3. Raise the front of the machine by jacking at the center front flat surface of the solution tank.
4. Using a 5mm hex key, remove the four screws (38) that secure the drive hub (40) to the internal gearbox.
5. Using a 5mm hex key, remove the six screws (39) that secure the drive hub to the tire (wheel).
6. Insert the four wheel puller bolts (41) through the drive housing, and hand tighten them until they equally touch the metal wheel portion of the tire assembly.
7. Using a 5mm hex key, gradually tighten each bolt at about 1/2 to 1 turn at a time. Work in a crisscross pattern so each bolt pushes the wheel off the main bearing (42) equally. (The wheel hub (40) will come free after just a few turns.)

For reference, the wheel/tire presses over the main bearing (42). The drive hub (40) is lightly pressed onto the tapered disk (43) of the gearbox.

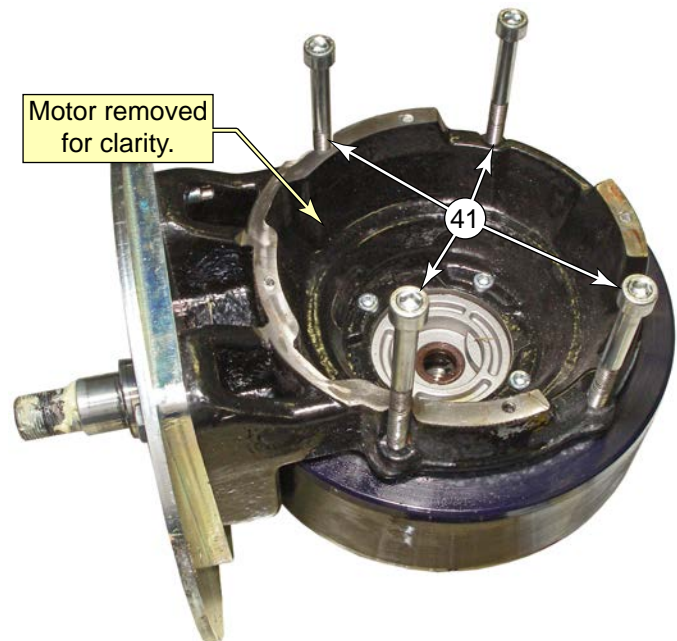
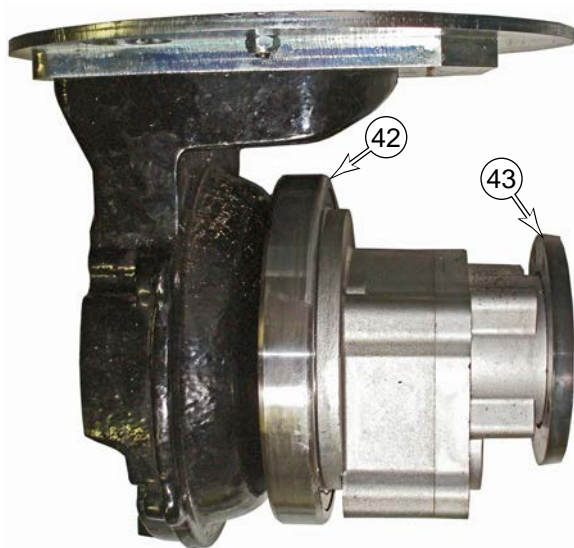
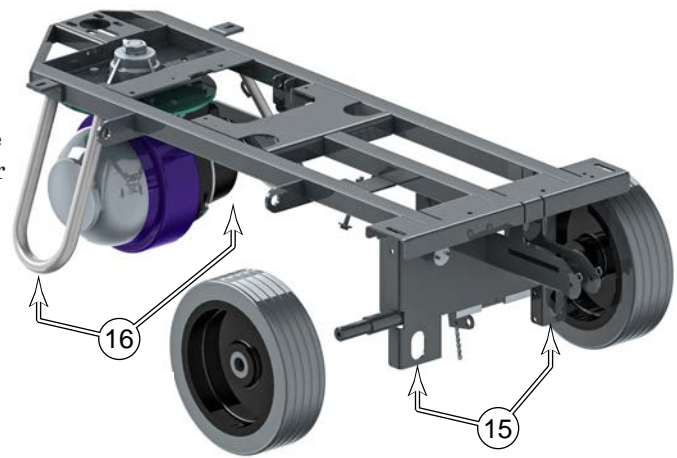

Replacement Notes

1. Install the drive hub (40) to the new wheel/tire using the six socket head cap screws (39).
2. Remove the tire pulling bolts (41) from the drive housing.
3. Lightly install the two alignment pins (44) into two of the threaded holes of the gearbox output disk (43).
4. Slide the drive hub (with the new wheel/ tire) over the alignment pins.
5. Gently tap on the upper portion of the drive hub (40) to get the wheel started over the main bearing (42) until the mounting screws (38) can be started in their threads.
6. Remove the alignment pins (44), and replace them with the two remaining mounting screws (38).
7. In small increments, simultaneously tighten all four mounting screws to pull the drive hub tight to the gearbox output disk (43).
8. Finish reassembling the machine by reversing the disassembly steps.

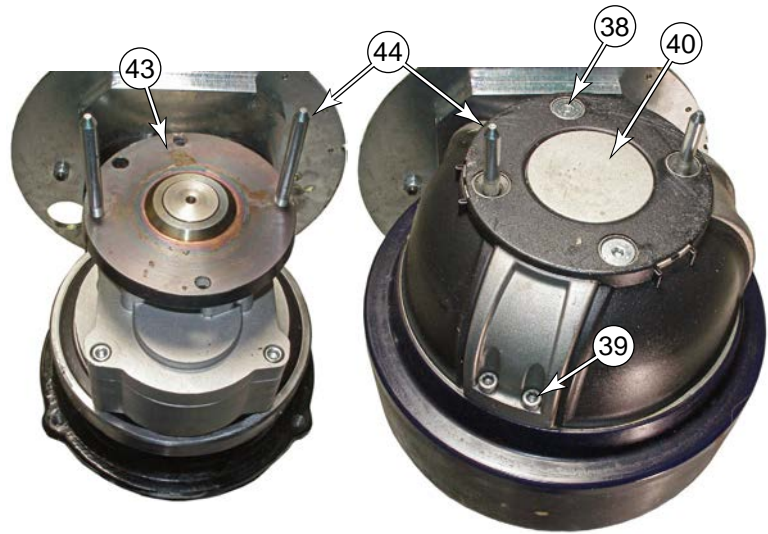

Steering Chain



Warning: Never work under machine without safety stands or blocking to support the machine.

1. Turn off the key and disconnect the batteries.
2. To reduce the weight of the machine, drain both the recovery and solution tanks. To lower the center of gravity of the machine, you may even choose to remove the recovery tank from the machine.
3. Block both sides of the machine at the rear lifting points (15) to keep the machine stable and prevent it from rolling. To prevent tipping, it is also a good idea to chain the machine down at the rear lifting points.
4. Raise the front of the machine by jacking at the center front flat surface of the solution tank.
5. Block the front of the machine at the forward anchor points (16) so the jacking device can be removed.
6. Remove the two master links (23) from the steering chain, and remove the chain from the chain disk (10).

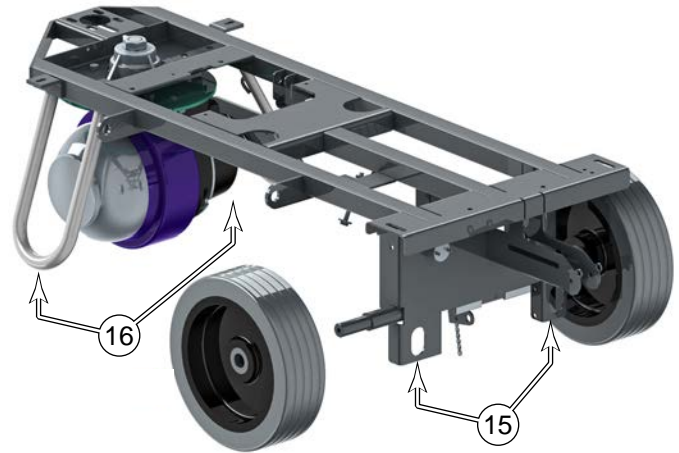

Reassembly Notes

After reinstalling the chain, it may be necessary to adjust the chain tension described below.

1. Loosen the four bolts (46) that secure the steering column to the frame.
2. Slide the steering column forward or backward to tension the chain. The chain should be adjusted to provide 1/4" of deflection at the midpoint (47).

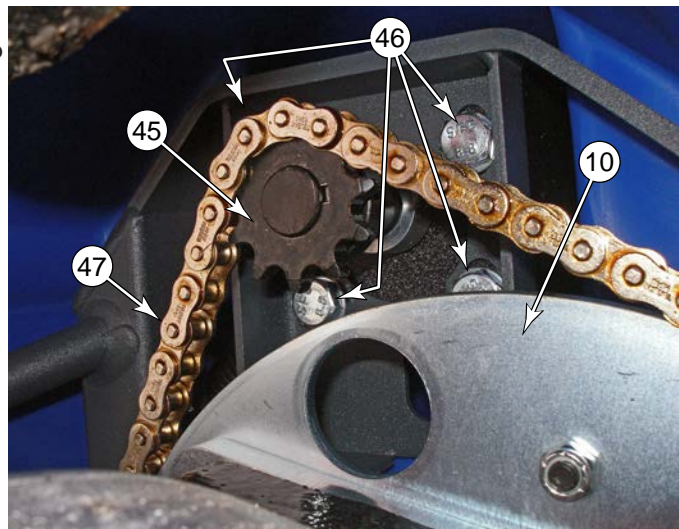
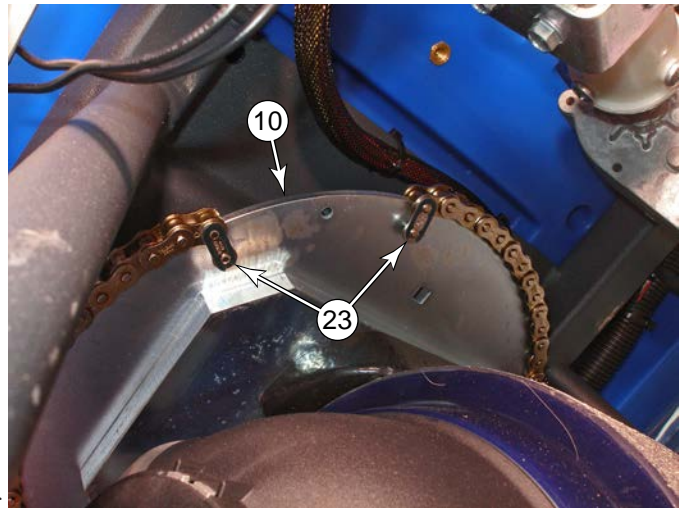

Specifications

Parameter	Range
Brake Coil Resistance	• 24.7 Ω
Wheel Motor Amperage	• No Load = 8.3 A, Typical Transport = 13.7 - 15.1 A
Throttle Potentiometer Resistance	• Total = 5.2 k Ω

Speed Controller Sample Voltage Measurements					
Pin #	Name	V-On	V-Off	Ref.	Comments
1	Not Used			B-	
2	Not Used			B-	
3	Pot Hi	4.54	N/A	B-	Speed potentiometer high reference
4	Pot Wiper	4.18	0.04	B-	Speed potentiometer wiper
5	KSI	25.1	0	B-	Safety circuit to enable drive controller
6	Brake Out(-)	0.25	23.1	B-	Drive wheel brake
7	Not Used			B-	
8	Not Used			B-	
9	Status	Data	1.2	B-	Status output to the main machine controller (24 volt pulses)
10	Not Used			B-	
11	Not Used			B-	
12	Not Used			B-	
13	Pot Low	0.42	N/A	B-	Speed potentiometer low reference
14	Brake Out(+)	25.6	0	B-	Drive wheel brake
15	Not Used			B-	
16	Rev/Alarm	1.6	25.1	B-	Output indicating when machine is moving in reverse
17	Fwd/Rev	23.8	0	B-	Output indicating when machine is in motion
18	Spd Lmt Pot	†	N/A	B-	† 4Bar = 4.5, 3Bar = 3.4, 2Bar = 2.8, 1Bar = 2.3

Special Tools

Curtis 1311 Programmer PN 56409441

The Curtis 1311 Programmer (or the 1307 predecessor) may be used to display drive controller error codes and program the drive controller. With a programmer, diagnostics and troubleshooting is more direct than with the Focus II display alone. The programmer presents complete diagnostic information in plain language without codes to decipher. Faults are displayed in the Diagnostic Menu, and the status of the controller inputs/outputs is displayed in the Test Menu.

The handheld programmer can also be used to access the drive controller's diagnostic history file. This file contains the history of cleared error codes, which may be helpful in determining the functional status of the machine between service intervals.

Refer to the Curtis 1311 Programmer manual for further information regarding the use and operation of the handheld programmer.



Tire "Puller" Kit PN 56422174

